

# LV - Power Quality Products & Solutions

Catalogue 2014



# Our vision



We see a world where innovative individuals **use collaborative solutions to make the most of their energy**, while using less of our common planet

We enable people to experience and transform efficiency where they live and where they work, from home to enterprise to grid

Moving towards an active energy management architecture from Plant to Plug through EcoStruxure, because integration is the key to efficiency



## > Schneider Electric in India



**19000 +**  
employees



**31**  
Global Manufacturing Plants



**10 +**  
Distribution Centres



**1800 +**  
Authorised Partners Distributors  
System Integrators, Panel Builders



**1000 +**  
R&D engineers in Bangalore



**1**  
Regional Project & Engineering Centre

# Your requirements....

---

## Optimize energy consumption

- By reducing electricity bills
- By reducing power losses
- By reducing CO<sub>2</sub> emissions

## Increase the power availability

- Compensate for voltage sags detrimental to process operation
- Avoid nuisance tripping and supply interruptions

## Improve your business performance

- Optimize the installation size
- Reduce harmonic distortion to avoid the premature ageing of equipment and destruction of sensitive components



# Our solutions....

---

## Reactive energy management

In electrical networks, reactive energy is responsible for increased line currents, for a given active energy transmitted to loads.

### The main consequences are

- Necessary over sizing of transmission and distribution networks by the Utilities
- Increased voltage drops and sags along the distribution lines
- Additional power losses



This is resulting in increased electricity bills for industrial customers because of

- Penalties applied by most Utilities to reactive energy,
- Increased overall kVA demand,
- Increased energy consumption within the installations.

Reactive energy management aims to optimize your electrical installation by reducing energy consumption, and improve power availability. CO<sub>2</sub> emissions are also globally reduced.



5 to 10%  
reduction in  
utility power bills

Reduce  
energy cost  
by improving  
electrical networks

# Improve electrical networks and reduce energy costs

## Power Factor Correction

Every electric machine needs active power (kW) and reactive power (kVAr) to operate. The power rating of the installation in kVA is the combination of both:

$$(kVA)^2 = (kW)^2 + (kVAr)^2 \quad \text{or} \quad kVA = \sqrt{kW^2 + kVAr^2}$$

The Power Factor has been defined as the ratio of active power (kW) to apparent power (kVA).

$$\text{Power Factor} = (kW) / (kVA).$$

The objective of Reactive Energy management is improvement of Power Factor, or "Power Factor Correction".

This is typically achieved by producing reactive energy close to the consuming loads, through connection of capacitor banks to the network.

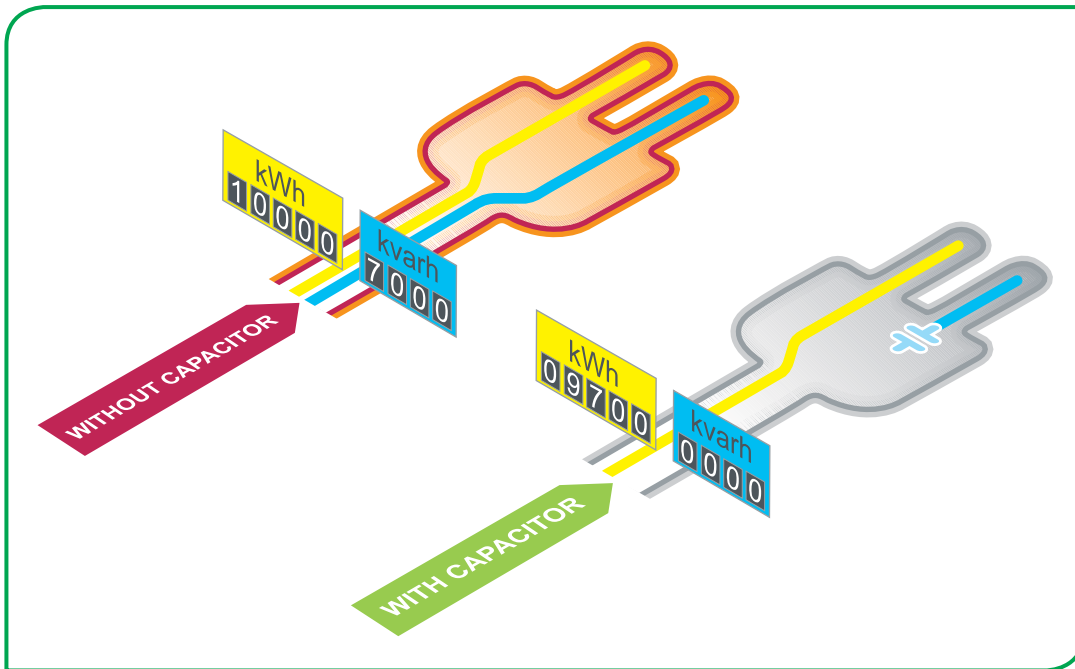

# Ensure reliability and safety at installations



## Quality and reliability

- Continuity of service thanks to the high performance and long life expectancy of capacitors.
- 100% testing in manufacturing plant.
- Design and engineering with the highest international standards.

## Safety

- Tested safety features integrated on each phase.
- Over-pressure system for safe disconnection at the end of life.
- All materials and components are free of PCB pollutants.

## Efficiency and productivity

- Product development including innovation in ergonomics and ease of installation and connection.
- Specially designed components to save time on installation and maintenance.
- All components and solutions available through a network of distributors and partners in more than 100 countries.



Schneider Electric ranks as the global specialist in Energy management providing a unique and comprehensive portfolio. Thanks to the know-how developed over 50 years. Schneider Electric helps you to make the most of your energy with innovative, reliable and safe solutions.



# Quality & Environment



## Quality certified ISO9001 and ISO 14001

### A major strength

In each of its manufacturing units, Schneider Electric has an operating organization whose main role is to verify quality and ensure compliance with standards. This procedure is:

- Uniform for all departments;
- Recognized by numerous customers and official organizations.

But, above all, its strict application has made it possible to obtain the recognition of independent organizations.

The quality system for design and manufacturing is certified in compliance with the requirements of the ISO9001 and ISO 14001 Quality Assurance model.

### Stringent, systematic controls

During its manufacture, each equipment item undergoes systematic routine tests to verify its quality and compliance:

- Measurement of operating capacity and tolerances;
- Measurement of losses;
- Dielectric testing;
- Checks on safety and locking systems;
- Checks on low-voltage components;
- Verification of compliance with drawings and diagrams.

The results obtained are recorded and initialled by the Quality Control Department on the specific test certificate for each device.

### RoHS, REACh compliance

All LV PFC components of Schneider Electric are RoHS , REACh compliant.



Schneider Electric undertakes to reduce the energy bill and CO<sup>2</sup> emissions of its customers by proposing products, solutions and services which fit in with all levels of the energy value chain. The Power Factor Correction and harmonic filtering offer form part of the energy efficiency approach.

## General contents

---

Power Factor Correction Guidelines	A
Factors Relating to Harmonics and Operating Conditions	B
Solutions for Harmonic Rich Environment	C
Capacitor Selection Criteria	D
Selection of Capacitor (kVAr & voltage) for Detuned Filter Application	E
Low Voltage Capacitors	F
Detuned Reactors	G
Power Factor Controllers and Contactors	H
Installation Guide and Annexures	I

---







# Power Factor Correction Guidelines

LV - Power Quality Products  
& Solutions

Why Reactive Energy Management?  
Method for Determining Compensation

---

A-2  
A-5



# Why reactive energy management?

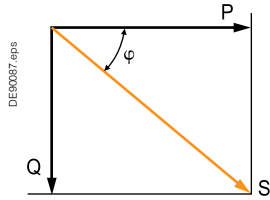

In this representation, the Power Factor ( $P/S$ ) is equal to  $\cos\phi$ .

Due to this higher supplied current, the circulation of reactive energy in distribution networks results in:

- > Overload of transformers
- > Higher temperature rise in power cables
- > Additional losses
- > Large voltage drops
- > Higher energy consumption and cost
- > Less distributed active power.

## Principle of reactive energy management

All AC electrical networks consume two types of power: active power (kW) and reactive power (kVAr):

- **The active power P** (in kW) is the real power transmitted to loads such as motors, lamps, heaters, computers, etc. The electrical active power is transformed into mechanical power, heat or light.
- **The reactive power Q** (in kVAr) is used only to power the magnetic circuits of machines, motors and transformers.

The apparent power S (in kVA) is the vector combination of active and reactive power.

The circulation of reactive power in the electrical network has major technical and economic consequences. For the same active power P, a higher reactive power means a higher apparent power, and thus a higher current must be supplied.

The circulation of active power over time results in active energy (in kWh). The circulation of reactive power over time results in reactive energy (kvarh).

In an electrical circuit, the reactive energy is supplied in addition to the active energy.

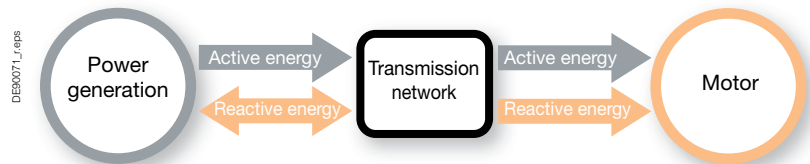

Reactive energy supplied and billed by the energy provider.

For these reasons, there is a great advantage in generating reactive energy at the load level in order to prevent the unnecessary circulation of current in the network. This is what is known as "power factor correction". This is obtained by the connection of capacitors, which produce reactive energy in opposition to the energy absorbed by loads such as motors.

The result is a reduced apparent power, and an improved power factor  $P/S'$  as illustrated in the diagram opposite.

The power generation and transmission networks are partially relieved, reducing power losses and making additional transmission capacity available.

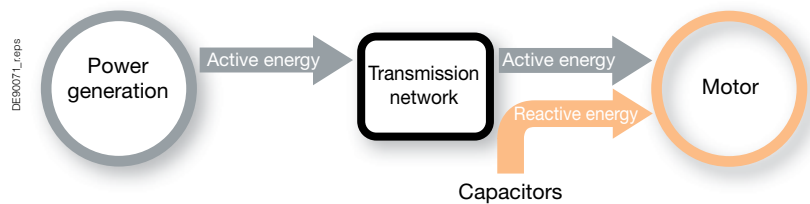
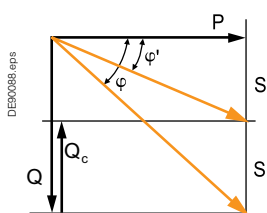

The reactive power is supplied by capacitors. No billing of reactive power by the energy supplier.



## Benefits of reactive energy management

Optimized management of reactive energy brings economic and technical advantages.

### Savings on the electricity bill

- > Eliminating penalties on reactive energy and decreasing kVA demand.
- > Reducing power losses generated in the transformers and conductors of the installation.

*Example:*

*Loss reduction in a 630 kVA transformer PW = 6,500 W with an initial Power Factor = 0.7.*

*With power factor correction, we obtain a final Power Factor = 0.98.*

*The losses become: 3,316 W, i.e. a reduction of 49 %.*

$$\begin{aligned} \text{Copper loss} &= \left(\frac{\text{PF}_1}{\text{PF}_2}\right)^2 \times \text{Full load copper loss} \\ &= \left(\frac{0.7}{0.98}\right)^2 \times \text{Full load copper loss} \\ &= \left(\frac{0.7}{0.98}\right)^2 \times 6500 \text{ W} \\ &= 3316 \text{ W} \end{aligned}$$

$$\begin{aligned} \text{Savings} &= 6500\text{W} - 3316\text{W} \\ &= 3183\text{W} \end{aligned}$$

### Increasing available power

A high power factor optimizes an electrical installation by allowing better use of the components. The power available at the secondary of a MV/LV transformer can therefore be increased by fitting power factor correction equipment on the low voltage side.

The table shows the increased available power at the transformer output through improvement of the Power Factor from 0.7 to 1.

*Example*

*Calculation for additional load in kW that can be connected by improving Power Factor*

*Load = 500 kVA*

*Initial PF(cosφ<sub>1</sub>) = 0.7*

*Target PF (cosφ<sub>2</sub>) = 0.95*

*cosφ<sub>1</sub> = kW<sub>1</sub> / kVA<sub>1</sub>*

*kW<sub>1</sub> = kVA x cosφ<sub>1</sub>*  
*= 350 kW*

*kW<sub>2</sub> = kVA x cosφ<sub>2</sub>*  
*= 475 kW*

*Additional kW that can be connected = 475 - 350 = 125 kW*

*% of additional load = 125 / 350 x 100 = 36%*

Power factor	Increased available power
0.7	0 %
0.8	+ 14 %
0.85	+ 21 %
0.90	+ 28 %
0.95	+ 36 %
1	+ 43 %



## Reducing installation size

Installing power factor correction equipment allows conductor cross-section to be reduced, since less current is absorbed by the compensated installation for the same active power.

The opposite table shows the multiplying factor for the conductor cross-section with different power factor values.

Example

Calculation of reduction of line current if PF improved from 0.60 to 1.00

$$\text{Load} = 350 \text{ kW}$$

$$\text{kVA}_1 = \text{kW}/\text{PF}_1$$

$$= 350 / 1.00$$

$$= 350 \text{ kVA}$$

$$I_1 = \text{kVA} \times (1000 / \sqrt{3}) / V$$

$$= 583 \times (1000 / \sqrt{3}) / 440$$

$$= 765 \text{ A (Before PF compensation)}$$

$$\text{kVA}_2 = \text{kW}/\text{PF}_2$$

$$= 350/0.60$$

$$= 583 \text{ kVA}$$

$$I_2 = \text{kVA} \times (1000 / \sqrt{3}) / V$$

$$= 350 \times (1000 / \sqrt{3}) / 440$$

$$= 459 \text{ A (After PF compensation)}$$

Power factor	Cable cross-section multiplying factor
1	1
0.80	1.25
0.60	1.67
0.40	2.50

Savings in line current Multiplying Factor

$$= I_1 / I_2$$

$$= 765 / 459$$

$$= 1.67$$

## Reducing voltage drops in the installation

Installing capacitors allows voltage drops to be reduced upstream of the point where the power factor correction device is connected.

This prevents overloading of the network and reduces harmonics, so that you will not have to overrate your installation.

$$\frac{\Delta V}{V} = \frac{Q}{S}$$

$\Delta V$  = Voltage Improvement

$V$  = System Voltage Without Capacitors

$Q$  = Capacitors Rating in MVar

$S$  = System Fault Level In MVA

Example:

For a 150 kVar, 440V capacitor & System fault level of 15 MVA

$$\frac{\Delta V}{V} = \frac{Q}{S}$$

$$\frac{\Delta V}{440} = \frac{150 \times 0.15}{15}$$

$$\Delta V = 4.4 \text{ Volts}$$

# Method for determining compensation

The selection of Power Factor Correction equipment can follow a 4-step process:

**Step - 1**

Calculation of the required reactive energy.

**Step - 2**

Selection of the compensation mode:

- Central, for the complete installation
- By sector
- For individual loads, such as large motors.

**Step - 3**

Selection of the compensation type:

- Fixed, by connection of a fixed-value capacitor bank;
- Automatic, by connection of a number of steps, allowing adjustment of the reactive energy to the required value;
- Dynamic, for compensation of highly fluctuating loads.

**Step - 4**

Factors relating to harmonics and operating conditions

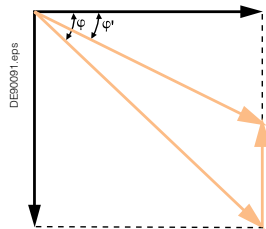

## Step 1: Calculation of the required reactive power

The objective is to determine the required reactive power  $Q_c$  (kVAr) to be installed, in order to improve the power factor  $\cos \phi$  and reduce the apparent power  $S$ .

For  $\phi' < \phi$ , we obtain:  $\cos \phi' > \cos \phi$  and  $\tan \phi' < \tan \phi$ .

This is illustrated in the diagram opposite.

$Q_c$  can be determined from the formula  $Q_c = P \cdot (\tan \phi - \tan \phi')$ , which is deduced from the diagram.

$Q_c$  = power of the capacitor bank in kVAr.

$P$  = active power of the load in kW.

$\tan \phi$  = tangent of phase shift angle before compensation.

$\tan \phi'$  = tangent of phase shift angle after compensation.

The parameters  $\phi$  and  $\tan \phi$  can be obtained from billing data, or from direct measurement in the installation.

The following table can be used for direct determination.

Before compensation		Reactive power (kVAr) to be installed per kW of load, in order to get the required $\cos \phi'$ or $\tan \phi'$							
		$\tan \phi'$	0.75	0.62	0.48	0.41	0.33	0.23	0.00
		$\cos \phi'$	0.80	0.85	0.90	0.925	0.95	0.975	1.000
$\tan \phi$	$\cos \phi$								
1.73	0.5		0.98	1.11	1.25	1.32	1.40	1.50	1.73
1.02	0.70		0.27	0.40	0.54	0.61	0.69	0.79	1.02
0.96	0.72		0.21	0.34	0.48	0.55	0.64	0.74	0.96
0.91	0.74		0.16	0.29	0.42	0.50	0.58	0.68	0.91
0.86	0.76		0.11	0.24	0.37	0.44	0.53	0.63	0.86
0.80	0.78		0.05	0.18	0.32	0.39	0.47	0.57	0.80
0.75	0.80		0.13	0.27	0.34	0.42		0.52	0.75
0.70	0.82			0.08	0.21	0.29	0.37	0.47	0.70
0.65	0.84			0.03	0.16	0.24	0.32	0.42	0.65
0.59	0.86				0.11	0.18	0.26	0.37	0.59
0.54	0.88				0.06	0.13	0.21	0.31	0.54
0.48	0.90					0.07	0.16	0.26	0.48

Example: consider a 1000 kW motor with  $\cos \phi = 0.8$  ( $\tan \phi = 0.75$ ). In order to obtain  $\cos \phi = 0.95$ , it is necessary to install a capacitor bank with a reactive power equal to  $k \times P$ , i.e.:  $Q_c = 0.42 \times 1000 = 420$  kVAr.

Total kVAr = kw x multiplying factor

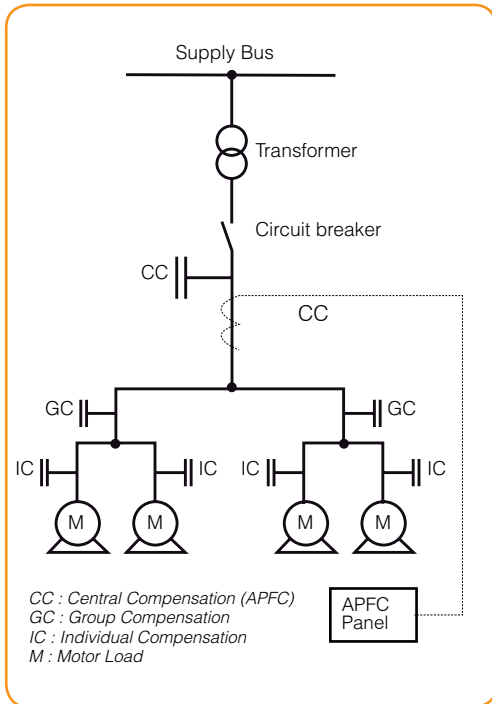

## Step 2: Selection of the compensation mode

The location of low-voltage capacitors in an installation constitutes the mode of compensation, which may be central (one location for the entire installation), by sector (section-by-section), at load level, or some combination of the latter two. In principle, the ideal compensation is applied at a point of consumption and at the level required at any moment in time.

In practice, technical and economic factors govern the choice.

The location for connection of capacitor banks in the electrical network is determined by the:

- overall objective (avoid penalties on reactive energy relieve transformer or cables, avoid voltage drops and sags)
- Operating mode (stable or fluctuating loads)
- Foreseeable influence of capacitors on the network characteristics
- Installation cost.

### 1. Central compensation (CC)

The capacitor bank is connected at the head of the installation to be compensated in order to provide reactive energy for the whole installation. This configuration is convenient for a stable and continuous load factor.

### 2. Group compensation (GC)/by Sector

The capacitor bank is connected at the head of the feeders supplying one particular sector to be compensated. This configuration is convenient for a large installation, with workshops having different load factors.

### 3. Compensation of individual loads (IC)/Motors

The capacitor bank is connected right at the inductive load terminals (especially large motors). This configuration is very appropriate when the load power is significant compared to the subscribed power.

This is the ideal technical configuration, as the reactive energy is produced exactly where it is needed, and adjusted to the demand.



# Method for determining compensation

## Recommended kVAR for 3 phase AC Inductor Motors (IC compensation)

Capacitor rating in kVAR when motor speed (RPM) is:

Motor	3000 rpm	1500 rpm	1000 rpm	750 rpm	500 rpm
Rating in HP					
2.5	1	1	1.5	2	2.5
5	2	2	2.5	3.5	4
7.5	2.5	3	3.5	4.5	5.5
10	3	4	4.5	5.5	6.5
15	4	5	6	7.5	9
20	5	6	7	9	12
25	6	7	9	10.5	14.5
30	7	8	10	12	17
40	9	10	13	15	21
50	11	12.5	16	18	25
60	13	14.5	18	20	28
70	15	16.5	20	22	31
80	17	19	22	24	34
90	19	21	24	26	37
100	21	23	26	28	40
110	23	25	28	30	43
120	25	27	30	32	46
130	27	29	32	34	49
140	29	31	34	36	52
145	30	32	35	37	54
150	31	33	36	38	55
155	32	34	37	39	56
160	33	35	38	40	57
165	34	36	39	41	59
170	35	37	40	42	60
175	36	38	41	43	61
180	37	39	42	44	62
185	38	40	43	45	63
190	38	40	43	45	65
200	40	42	45	47	67
250	45	50	55	60	70

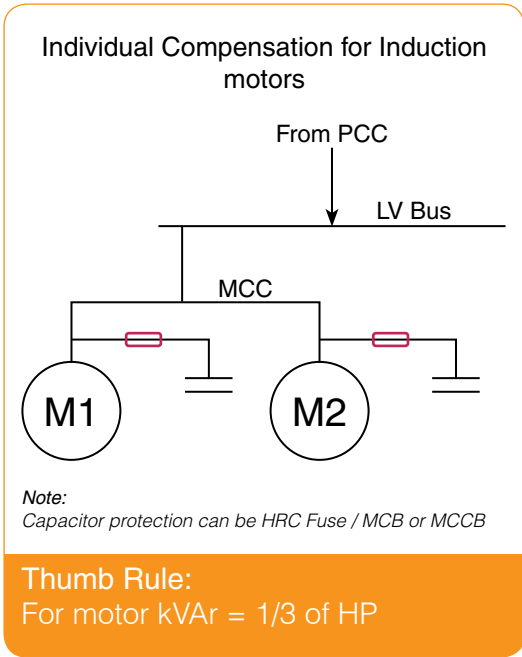

Method for determining Compensation general the capacitor current should be less than or equal to 90% of no load current of the motor.

## Recommended kVAR for transformer No-Load compensation

The transformer works on the principle of Mutual Induction. The transformers will consume reactive power for magnetizing purpose. Following equivalent circuit of transformer provides the details of reactive power demand inside the transformer:

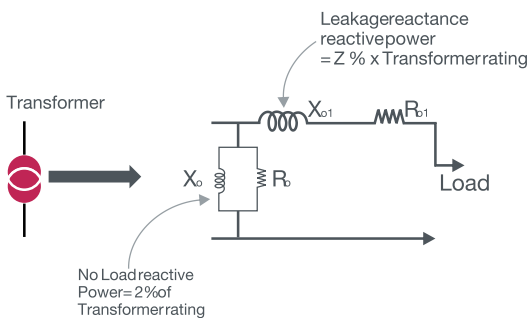

kVA rating of Transformer	kVAR required for No-Load compensation
Up to and including 2000 kVA	2% of kVA rating



50 kVAr unit

### Step 3: Selection of the compensation type

Different types of compensation should be adopted depending on the performance requirements and complexity of control:

- **Fixed** - by connection of a fixed-value capacitor bank
- **Automatic** - by connection of a different number of steps, allowing adjustment of the reactive energy to the required value
- **Dynamic** - for compensation of highly fluctuating loads.

#### a) Fixed compensation

This arrangement uses one or more capacitor(s) to provide a constant level of compensation. Control may be:

- Manual: by circuit-breaker or load-break switch
- Semi-automatic: by contactor
- Direct connection to an appliance and switched with it.

These capacitors are installed:

- At the terminals of inductive loads (mainly motors)
- At busbars supplying numerous small motors and inductive appliances for which individual compensation would be too costly
- In cases where the load factor is reasonably constant.

## Method for determining compensation



Non-Compartmentalized  
APFC panel

### b) Automatic Power Factor compensation panel (APFC)

This kind of compensation provides automatically the required reactive power according to the variations in load conditions in order to maintain the targeted  $\cos\phi$ . The equipment is installed at certain points in an installation where the active-power and/or reactive-power variations are relatively large, for example:

- on the busbars of a main distribution switchboard
- on the terminals of a heavily-loaded feeder cable.

Where the kVAr rating of the capacitors is less than or equal to 15% of the power supply transformer rating, a fixed value of compensation is appropriate. Above the 15 % level, it is advisable to install an automatically-controlled capacitor bank.

Control is usually provided by an electronic device (Power Factor Controller) which monitors the actual power factor and orders the connection or disconnection of capacitors in order to obtain the targeted power factor. The reactive energy is thus controlled by steps. In addition, the Power Factor Controller provides information on the network characteristics (voltage amplitude and distortion, power factor, actual active and reactive power...) and equipment status. Alarm signals are transmitted in case of malfunction.

Connection is usually provided by contactors. For compensation of highly fluctuating loads, fast and highly repetitive connection of capacitors is necessary, and static switches must be used.

- The basic operation of the APFC as follows
- To continuously sense and monitor the load conditions by the use of the external load CT (Whose output is fed to the controller).
- To automatically switch ON and switch OFF relevant capacitor steps to ensure consistent power factor.
- To ensure easy user interface for enabling reliable understanding of system operation, such as display real time power factor, number of switching operations are carried out.
- To protect against any electrical faults in a manner that will ensure safe isolation of the power factor correction equipment.

### Advantage

- Consistently high power factor under fluctuating load conditions
- Elimination of low power factor penalty levied by electrical supply authorities and avail the incentives as per Electricity board.
- Reduced kVA demand charges
- Prevention of leading power factor in an installation.

### Salient features

- Panel design which allows easy handling by the user.
- The incoming switchgear provided has 35/50kA for 1sec fault current
- Aluminum bus bar system suitable for the short time rating of 35/50kA for 1 sec
- Copper bus bar system suitable for the short time rating of 35 / 50kA for 1 sec. (on request)
- Minimal Jointing in all the connections to ensure better reliability and lower losses.
- Switchgear used such as contactors, Switch disconnects or, fuses, MCCB's etc. conform to the latest Indian and International Standards.
- Use of Special connecting power cables suitable for High temperature withstand up to 102°C
- Flush mounted meters to indicate line voltages and currents
- Advanced microprocessor controller
- Choice of constructional designs such as compartmentalized / Non compartmentalized etc.

## Method for determining compensation



*Compartmentalized APFC Panel*

- User friendly and aesthetically designed enclosure, designed and with IP42 enclosure.
- Well engineered design to achieve optimal compensation with minimum step ratings.
- Capacitor Duty contactor to reduce the inrush current to ensure the reliability of the capacitor.
- Use of proper ventilated design ensures better reliability of the entire system.

Standard APFC Range available: 100 kVAr to 600 kVAr contactor switching

### Applicable standards

IEC: 61921 (Power Capacitors- Low voltage power factor correction banks) is the international standard applicable for Low Voltage Power Factor Correction Banks and Automatic Power Factor Correction (APFC) equipments intended to be used for power factor correction purposes, equipped with built in switch gears and control gears. The guidelines for design, installation, operation and safety of APFC panels are followed based on this international standard.

The design of the Low Voltage Power Factor Correction banks and accessories comply with the following standards

- IEC60831: Part 1 & 2-Shunt power capacitors of the self healing type for A.C systems having rated voltage up to and including 1kV.
- IEC 60439-3: for low voltage switchgear and control gear assemblies.  
IEC 60947: Low Voltage Switchgear  
Part 2: Molded Case Circuit Breakers & Air circuit Breakers  
Part 4: Power Contactors  
Part 4-3: Thyristor Switch
- IEC 60269: LV Fuses
- IEC 60076-6 : Reactors
- IEC 60529: Degree of protection provided by enclosure (IP code)
- IEC 60044-1: Current transformers.
- IEC 60664-1 / IEC 61326: Power Factor Controller.

# Method for determining compensation

## General technical particulars

Standard	IEC -61921
Rated Voltage	415/440V
Rated Frequency	50 Hz
Power Supply	3 phase / 4 wire
Enclosure	CRCA sheet steel, Non-compartmentalized Colour-RAL7035.
Installation	Indoor, Floor mounted, cable entry from bottom.
Incomer	MCCB, 3 pole, 35kA
Step Protection	MCCB/MCB
Capacitors	Varplus Can / Varplus Box
Step Switching	Capacitor Duty contactors with Damping Resistors
Emergency Pushbutton	Provided to interrupt the power supply during emergency.
Phase Indicating	L1, L2, L3 indicating lamps provided.
Protection Class	IP 42.
Switching Option	Auto-Manual / Auto
Bus bar	Aluminium / Copper



DYAPFC panel

### c) Dynamic compensation panel (DYAPFC)

Automatic power factor correction for normal fluctuating loads has already been explained. However, there are certain loads which demand, under certain operating conditions, large amount of reactive power for very short duration of time.

#### Typical examples are:

- Welding equipment
- Automobile industry
- Steel plants
- Injection moldings equipment
- Traction loads such as lifting cranes, elevators, lifts etc

The large demand of reactive power by such loads during operation can cause;

- System instability
- Over sizing of electrical installation since the kVA capacity will have to be provided for maximum power demand.
- Malfunctioning of sensitive electrical and electronic equipment such as relays, PLC etc.

These ill- effects can be overcome by injecting into the network defined amount of reactive power at a very fast rate which can meet the demand of such loads.

It is therefore necessary to use the “Thyristor” automatic power factor correction system. This system is a dynamic power factor correction system in which the switching and controlling devices used have a response time in milliseconds. The switching devices used are Thyristors and the controller is a special fast acting device which is capable of very fast response.

These systems make the use of Power capacitors, Thyristors and associated control/ firing circuits for fast response time. In the system it is possible to switch capacitors such that the inrush transient currents are totally eliminated. In addition the capacitors can be switched repetitively without any limits since; there is no need for allowing discharge of the capacitor before it is switched in.





# Factors Relating to Harmonics and Operating Conditions

LV - Power Quality Products  
& Solutions

Factors Relating to Harmonics and Operating Conditions

B-2



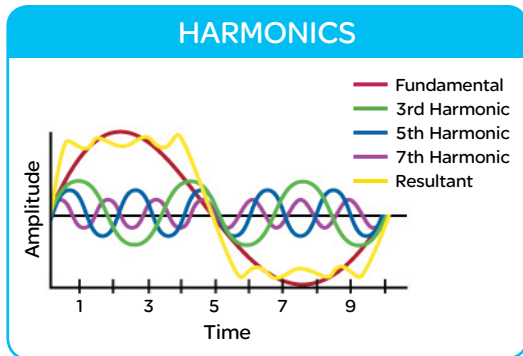

## What are Harmonics?

Harmonics are sinusoidal current/voltage whose frequency is integral multiple of fundamental frequency. Harmonic currents are caused due to wave chopping/modification used in voltage/frequency converters. The flow of harmonic current through system impedance will create voltage harmonics. The superposition of harmonic voltage on incoming voltage will alter the incoming supply voltage waveform.

Loads can be classified in to two families:

- Linear loads,
- Non linear loads.

A load is said to be linear when its current has the same waveform as the applied voltage.. for ex: AC Motors, Incandescent lamps, Resistive heating elements, Inductors, Capacitors etc are linear loads.

A load is said to be non-linear when its current has different waveform as compared to applied voltage. Such as ... UPS, AC/DC Drives, Steel furnaces, Battery chargers etc.

Pictures are presented typical current waveforms for single-phase (top) and three-phase non linear loads (bottom).

Single - Phase

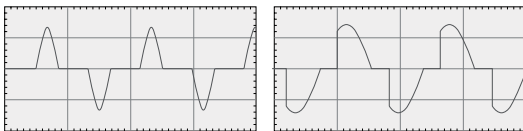

Three - Phase

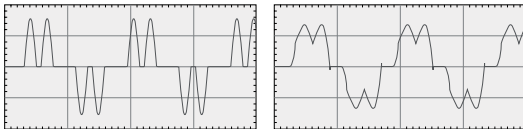

## Impact of non linear loads on R.M.S. current

The presence of harmonic current will increase the total RMS current supplied to the load . For example : If the fundamental current of particular load is 100A, and the harmonic current is 30A in magnitude, then the total RMS current of this load will be about 4% higher than the fundamental current.

Higher RMS current due to harmonic will have impact on the total capacity of the feeder. This may call for over sizing of feeder, transformer, circuit breaker, power source etc, impacting Capital investment.

## Factors relating to harmonics and operating conditions

### Heating

The flow of harmonic current in conductors will increase the losses due to skin effect. The resistance of a conductor will increase with frequency, hence for high frequency harmonic current, the resistance offered by a conductor such as Bus bar, Cables, Circuit breakers etc will be higher, and consequently the heating will be more. This may call for over sizing Cables, bus bars, Circuit breakers, ventilation system, impacting capital investment.

### Impact on active power

The presence of harmonic current/voltage will increase the power consumption of rotating machines such as Induction motors, Generating sets due to pulsating/negative torque.

### Impact on devices connected in series with non linear loads

Connected in series with non linear loads, we will find cables, circuit breaker, transformers. r.m.s. current will produce additional losses and these components may need to be oversized. This will increase the cost of the equipment. If the current at the front end of the manufacturing plant has a high content of harmonics, the incoming transformer will have to be oversized and the contract subscribed with the energy supplier will cost more.

### Impact on devices connected in parallel with non linear loads

Distorted current is likely to produce a distorted voltage with severe consequences: devices connected to the network may trip and cause plant shutdown, or the current in capacitor bank, used to correct the power factor, can increase drastically. Eventually resonance may occur causing dangerous over voltages.

### Economical consequences of harmonics

The major consequences of harmonics are the increase of the r.m.s. current in the different circuits and the deterioration of the supply voltage quality. The negative impact may remain unnoticed, with economical adverse results.

That is why a proper harmonic mitigation will contribute to improve competitiveness of companies in different ways:

- Reduced overloading on the electrical system, thereby releasing useable capacity,
- Reduced system losses and demand power,
- Reduced risks of outage,
- Extended equipment lifetime.

The total harmonic distortion THD is the usual parameter to evaluate the level of distortion of an alternating signal. The voltage distortion THD<sub>v</sub> is usually considered at the installation level, while the current distortion THD<sub>i</sub> is usually considered at the non linear equipment level.



# Solutions for Harmonic Rich Environment

LV - Power Quality Products  
& Solutions

Solutions for Harmonic Rich Environment

C-2



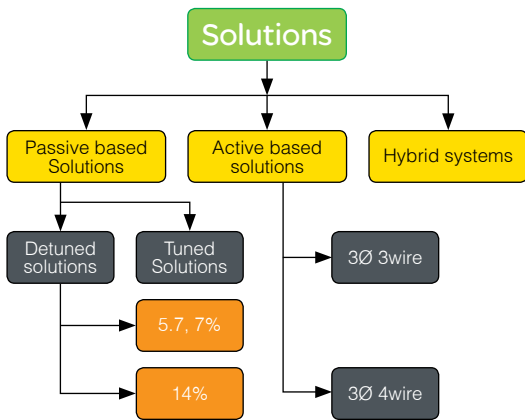

Depending on the magnitude of harmonics in the network the different configurations shall be adopted

- **Harmonic Filters**
  - > Detuned Filters
  - > Tuned Filters
- **Active Filters**
  - > Three phase 3 wire
  - > Three phase 4 wire
- **Hybrid Filter**
  - > Combination of passive and activefilters. Active filters for harmonic reduction and passive filter for PF improvement.

### Detuned filters

Detuned filters are the most preferred since they are cost effective solutions which work on the principle of avoiding resonance by achieving an inductive impedance at harmonic frequencies. The tuning frequency is generally lower than 90% of the lowest harmonic frequency whose amplitude is significant and which operate in a stable manner under various network configurations and operating conditions.

Detuned harmonic filter systems consist of Reactor(L) in series with a Capacitor (C) as shown in figure.

$$F_r = 1/(2\pi \sqrt{LC})$$

### Tuned filters

If the self resonant frequency of LC filter is within 10% of the harmonic to be filtered, then the filter is called Tuned Filter. They are primarily used as harmonic absorption filters and are generally more bulky and expensive. A harmonic study is required to design this filter. A computer simulation is required to verify the filter performance at all loading levels.

### Application

Reactors have to be associated with capacitor banks for Power Factor correction in systems with significant non-linear loads generating harmonics.

Capacitors and reactors are configured in a series resonant circuit tuned so that series resonant frequency is below the lowest harmonic frequency present in the system. This configuration is called "Detuned capacitor Bank" and the reactors referred as "Detuned Reactors"

The use of Detuned reactors prevents harmonic resonance problems, avoid the risk of overloading capacitors and leads to reduction in Voltage harmonic distortion in the network.

The tuning frequency can be expressed by the relative impedance of the reactor(in %) or by the tuning order or directly in Hz .

The most common values of relative impedance are 5.67% 7% and 14% is used with high level of 3rd harmonic voltages).

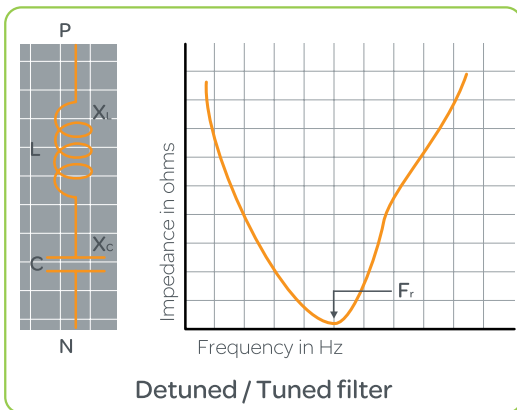





*Detuned filter APFC panel*

### Detuned automatic power factor correction panel (DAPFC)

A Harmonic rich environment is said to exist when the percentage of non-linear loads in an installation becomes greater than 25% of the connected load. Power factor correction by the use of capacitors, in such an environment, must therefore be carried out with certain precaution. This is due to the fact that parallel resonance conditions can occur. i.e. the magnitude of the capacitive reactance of capacitors installed and the inductive reactance of the network can tend to become equal.

If such resonance occurs near to a frequency which is present in the network, current amplification takes place. This current amplification can lead to overloading of capacitors and increase of the voltage distortion in the network. Consequently capacitors drawing higher current i.e. more than the rated current at normal operating voltages is a typical indication of presence of harmonics.

While it is possible to design the capacitors to withstand the over load conditions, the increase in distortion will cause other ill effect such as:

- Capacitors installed being subjected to serve harmonic overloading, leading to premature failure
- Total harmonic distortion in the network increasing beyond the permissible levels, which is harmful to various equipments within the installation.

Due to these reasons it is necessary to design and engineer a proper reactive energy management solution which will not only improve the average power factor of the installation but will also avoid harmonic current amplification and control harmonic distortion.

The use of capacitors in the conventional manner is therefore not recommended in such situations.

In order to achieve desired power factor correction and to avoid harmonic current amplification, detuned filter circuit must be used (refer IEC 61642).

### Benefits of using detuned filters

- Protect the capacitors from harmonic overloading
- Prevents current amplification
- Achieve consistently high power factor
- Prevents current amplification by avoiding series and parallel resonance.
- Reduces overloading of transformer and other rotating equipments.

### Fixed detuned filter components

In a detuned filter the capacitors used have to be rated for a higher voltage than the system voltages due to:

- Presence of series reactor and
- Absorption of harmonic currents in the detuned filter.

The reactors used will also have to be specifically designed to carry both fundamental and harmonic currents. The filter capacitors and reactors are available as standalone products so as to enable users to easily configure a fixed filter to suit requirement.



Accusine SWP

## Accusine SWP active harmonic filters

There are few instances where the passive filter cannot be used. For example, if wide spectrum of harmonics have to be filtered, the passive based solution may not be effective and impose significant limitations.

When harmonic mitigation is required, the logic measures the load current and calculates the harmonic current spectrum – that is the amplitude and phase angle for every harmonic to the 50th order. The logic then determines the amplitude to be injected at the opposite phase angle for each harmonic order selected for mitigation. Then a control signal is generated and the semiconductors (IGBT) are directed to duplicate the control signal as injected current into the supply. In this manner, the supply side harmonic current is greatly reduced.

The speed of response is controlled by:

- 1) the logic calculation method,
- 2) the switching rate of the IGBT (also identified as carrier frequency), and
- 3) the speed of the microprocessor in the control logic. The carrier frequencies and microprocessors are generally fast enough to provide per cycle response.

One type of logic employs fast Fourier transforms (FFT) that require three cycles of current to calculate the harmonic spectrum, thus requiring more than 3 cycles to begin injecting corrective current. AccuSine SWP employs FFT.

Another type of logic employs discrete spectrum logic (DSL) that uses one cycle of current to calculate the harmonic spectrum, thus providing less than 2 cycle response time for corrective action. AccuSine PCS employs DSL.

Correction for displacement PF calculates the phase shift of the fundamental current from the voltage of the supply on a per cycle basis. The control logic then calculates the amplitude and phase shift required to meet the user selected objective for displacement power factor. The IGBT are then directed to inject fundamental current at the proper phase shift to meet the objective. The actual displacement PF and objective may be leading (capacitive) or lagging (inductive). Near unity objectives can be met with no complications to the network. All AccuSine models perform displacement PF correction.

In a similar manner, the current required to correct for measured load unbalance (negative sequence current) is calculated and injected to balance the load for the supply. AccuSine PCS and AccuSine PFV are capable of providing Load Balancing.

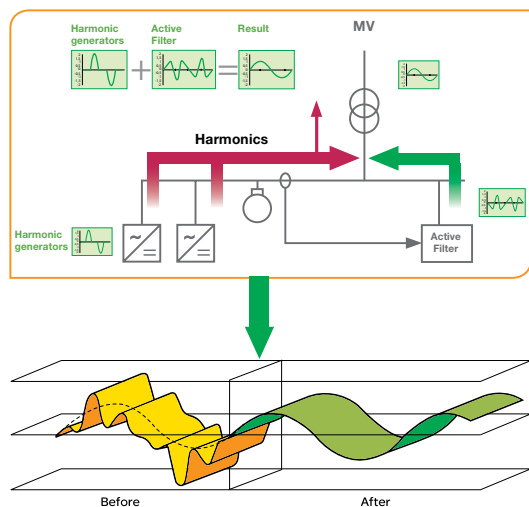

## Solutions for harmonic rich environment



Accusine PCS

### Accusine key features and main benefits

- Correction capacity per unit: 20, 30, 45, 60, 90, 120 Amperes.
- Voltage: base design 400 V AC 3-phase supply, other voltages with transformer.
- Harmonic compensation: H2 to H50, global or selective.
- Reactive compensation: power factor correction, close to near unity, selectable set point.
- Electrical systems: 3-wire or 4-wire.
- Neutral current correction: 3 times unit rating.
- Product standards: CE Certified.
- Parallel capability: up to 4 like units.
- Enclosure type: IP20, wall mounted.
- Communication: 3 dry (voltage free) contacts to monitor status from remote
- Location; Standard RS422/485 link for J-Bus and Modbus.
- Functionality: harmonic mitigation or power factor correction, separately or combined.
- Human Machine Interface: graphic display, seven languages.

### Performance capability

- Stepless automatic adaption to load changes.
- Suitable for all types and mixes of nonlinear loads.
- Fast response at < 2 cycles.
- Assist in compliance to any worldwide harmonic standards: IEEE 519, G5/4-1,GBT 14549, IEC-61000-3.
- THDi reduction to approximately 1/10 of network THDi.
- Corrects power factor, for IT servers to insure proper operation of UPS.
- Compatible with any type of neutral system.
- Harmonic current balancing on mains.

### Easy to control

- Three LED indicators for run, stop, and current limit.
- Very user friendly graphic terminal.
- Choice of seven languages.
- Parameters and notifications clearly displayed.
- Graphic display of THDu, THDi.
- Remote run/stop via RS 422/485 link via Modbus or J-Bus.
- Remote monitoring of parameters and notifications via RS 422/485 link via Modbus or J-Bus.

### Typical applications

- Data center & IT room.
- Offices and buildings.
- UPS systems.
- HVAC.
- Computer centers.
- Casinos.
- Power supplies for silicon production.

## Accusine Technical Specifications - SWP

Compensation capacity per phase( A rms)	20A,30A, 45A, 60A, 90A, 120A - 400V AC
Neutral compensation capacity	3 times rating
<b>System Input</b>	
Nominal Voltage	400VAC, +_10% Auto sensing: other voltage available with transformers
Nominal frequency	50/60Hz, +_3 % auto sensing
Number of phases	3-phase/3 wire, 3-phase/4-wire
Power switching devices	IGBT
Control topology	Digital
Operation with single phase loads	Yes
Current transformers ( CT)	400Hz & class 1 accuracy
	300,500,600,1000,1500,2000,3000,4000,5000 &6000A primary with 1A secondary, 3.5VA burden per unit
Quantity of CT's required	3
<b>Technical Characteristics</b>	
Harmonic cancellation spectrum	2nd to 50th, Discrete
RMS current attenuation	>10:1
Parallel configuration	4 units of same rating (master/slave)
Modes of Operation	Harmonic and Power Factor correction: independent or combined
Power factor correction	Leading( capacitive)or Lagging ( inductive) to target power factor
Priority assignment of modes	Harmonic cancellation
Response Time	< 2 cycles
Resonance avoidance	Detects and discontinues resonant frequency within 2 cycles
Voltage above base units design	To 15 kV
Internal overtemperature protection	Automatic roll backof output current
Display	Graphic display with keypad
Display languages	English
Operators	Keypad
HMI display parameters & graphics	LED for run, stop, current limit
	graphic display , mains voltage and current, load voltage and current,
	THDi -mains, THDi - load, event log, harmonic spectrum -mains & load
Communications Capability	J- Bus & Modbus
Acoustic Noise (ISO3746)	<_67 db at one meter from unit surface
Color	RAL 9002
<b>Environmental Conditions</b>	
Operating Temperature	0C to 40 C continuous ( derate 2 % / 1 C to 50C )
Relative humidity	0 - 95 % , noncondensing
Seismic qualification	IBC and ASCE7
Operating Altitude	1000m, ( derate 1%/100 m above)
Contamination levels ( IEC 60721 - 3 -3 )	Chemical Class 3C3 (1)
	Mechanical Class 3S3(2)
<b>Reference technical standards</b>	
Design	CE certified per CE EMC certification IEC/EN 60439-1, EN61000-6-4 Class A, EN61000-6-2
Protection ( enclosure)	IP20

**Note:** other ratings on request

## Solutions by Accusine Model

Accusine Model	Neutral Harmonics	Harmonic Mitigation	DPF Correction	Load Balancing	Var Support
Accusine SWP	√	√	√		
Accusine PCS		√	√	√	√
Accusine PFV			√	√	√

### AccuSine SWP

- Three or four wire connections (3 phase or 3-phase + Neutral).
- Up to 480 V supply; other possible with transformers.
- Units from 20 A to 120 A, parallel to 480 A.
- Cancellation to the 50th order.
- Neutral harmonic correction at 3 times unit rating.
- Displacement PF correction to set point.
- Modbus & J-bus communications.

### AccuSine PCS

- Three wire connection.
- From 208 V to 690 V supply (higher voltages with transformers).
- Units from 33 A to 300 A, parallel up to 99 units.
- Cancellation to 50th harmonic.
- Displacement PF correction to set point.
- Load balancing of input current.
- Rapid VAR injection in < 1 cycle.
- Modbus TCP/IP and Ethernet IP communications.
- Can be used with PF capacitors as Hybrid VAR Compensation (HVC) system.

### AccuSine PFV

- Three wire connection.
- From 208 V to 690 V supply (higher voltages with transformers).
- Units from 33 A to 300 A, parallel up to 99 units.
- Displacement PF correction to set point.
- Load balancing of input current.
- Rapid VAR injection in < 1 cycle.
- Modbus TCP/IP and Ethernet IP communications.
- Can be used with PF capacitors as Hybrid VAR Compensation (HVC) system.

## Active Filter - AccuSine SWP

### (Single Unit)

AMPS	Reference	Description
20	PCS020Y4IP20U	AccuSine SWP 20A 400V 50-60Hz IP20 Unitary
30	PCS030Y4IP20U	AccuSine SWP 30A 400V 50-60Hz IP20 Unitary
45	PCS045Y4IP20U	AccuSine SWP 45A 400V 50-60Hz IP20 Unitary
60	PCS060Y4IP20U	AccuSine SWP 60A 400V 50-60Hz IP20 Unitary
90	PCS090Y4IP20U	AccuSine SWP 90A 400V 50-60Hz IP20 Unitary
120	PCS120Y4IP20U	AccuSine SWP 120A 400V 50-60Hz IP20 Unitary

## Active Filter -- AccuSine SWP ( Parallel Unit application )

20	PCS020Y4IP20P	AccuSine SWP 20A 400V 50-60Hz IP20 Parallel
30	PCS030Y4IP20P	AccuSine SWP 30A 400V 50-60Hz IP20 Parallel
45	PCS045Y4IP20P	AccuSine SWP 45A 400V 50-60Hz IP20 Parallel
60	PCS060Y4IP20P	AccuSine SWP 60A 400V 50-60Hz IP20 Parallel
90	PCS090Y4IP20P	AccuSine SWP 90A 400V 50-60Hz IP20 Parallel
120	PCS120Y4IP20P	AccuSine SWP 120A 400V 50-60Hz IP20 Parallel



# Capacitor Selection Criteria

LV - Power Quality Products  
& Solutions

Capacitor Selection Criteria	D-2
Life Expectancy of Power Capacitors	D-4
Capacitor Selection Criteria	D-5



## Capacitor selection criteria



As various types of capacitors are manufactured therefore capacitor selection becomes a very tough decision for both the marketing personnel and end user. Capacitor selection methodology has been formulated by different capacitor manufacturers based upon following criteria.

- % Non-linear load connected
- Existing Harmonic THD(V) and THD (I) levels
- Number of switching of capacitors
- Detuned filter applications
- Environmental factors

### Life expectancy

- Capacitor Rated Voltage
- Permissible Over voltage
- Maximum permissible current
- Maximum ambient temperature
- Number of switching operations

No single criterion is fool proof and we have to use several of the above factors to arrive at the appropriate type of capacitor suitable for a given application.

Let us analyse each one of the above factors in detail and understand its limitations.



### % Non-linear load connected

This is the common practices to arrive at the capacitor duty based on the type of application.

- If the % non-linear load as compared to transformer capacity is below 10% it is recommended to use **Standard duty** capacitors.
- If % non-linear loads up to 20% it is recommended to use **Heavy duty** capacitors.
- If % non-linear loads up to 20% it is recommended to use **APP-**capacitors.
- If % non-linear loads up to 25% it is recommended to use **Energy** capacitors.
- If % non-linear loads between 25% to 50% it is recommended to use **Reactor + Capacitor (Detuned Filters)**
- If % non-linear loads above 50% it is recommended to use **active filter solution** for this a harmonic study is usually recommended in arriving at the most appropriate solution



## Calculation of non- linear load

Example

Installed Transformer rating = 2000 kVA (2MVA)

Non – linear Loads = 800 kVA

% Non – linear loads = (non-linear loads / Transformer rating) x 100  
= 800/2000 x 100  
= 40%

Recommended to use Detuned Filters

## Capacitor selection GTP

Type	Over Current Withstand Upto	Peak Inrush Current Withstand Upto	Ambient Temperature Withstand	Maximum Switching Frequency/Year	Life Expectancy (Hours) Upto	% of Non-linear Loads
Standard Duty	1.5 x I <sub>N</sub>	200 x I <sub>N</sub>	-25°C / +55°C (class D)	5000	100000	Up to 10%
Heavy Duty	1.8 x I <sub>N</sub>	250 x I <sub>N</sub>	-25°C / +55°C (class D)	7000	130000	Up to 20 %
Gas Heavy Duty	1.8 x I <sub>N</sub>	250 x I <sub>N</sub>	-25°C / +55°C (class D)	7000	130000	Up to 20 %
APP	2 x I <sub>N</sub>	350 x I <sub>N</sub>	-10°C / +50°C (class C)	8000	140000	Up to 20%
Energy ultra Heavy duty	2.5 x I <sub>N</sub>	400 x I <sub>N</sub>	-25°C / +70°C (class D)	10000	160000	Up to 25%

% of Non linear Loads between 25% to 50%	Use Reactor + capacitor ( Detuned Filters)
% of Non linear Loads above 50%	Use Active Filter solutions

## Life expectancy of power capacitors

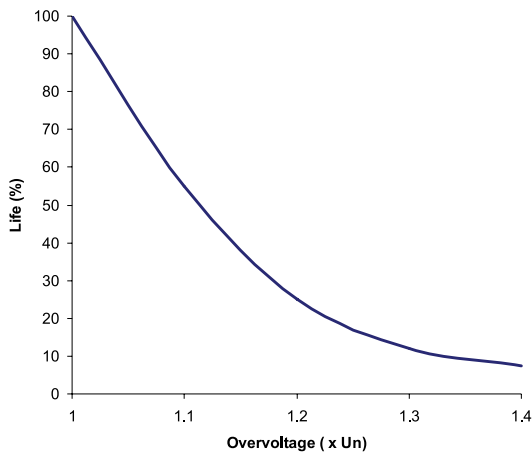

Change in capacitor life with respect to overvoltage factor  
(at constant temperature)

### Life expectancy of power capacitors

It is determined by several operating parameters. A few critical operating parameters are:

- Type and duration of overload (ex overcurrent, overvoltage)
- Maximum voltage level (including short duration overvoltages & overvoltages due to low load conditions)
- Active enclosure temperature and its increase due to increased ambient temperatures and high RMS capacitor currents (for Ex due to harmonics) If the above operating conditions are as per rated values, rated capacitor life can be expected. Similarly, a shorter capacitor life is obtained if the operating conditions are higher than the rated values.

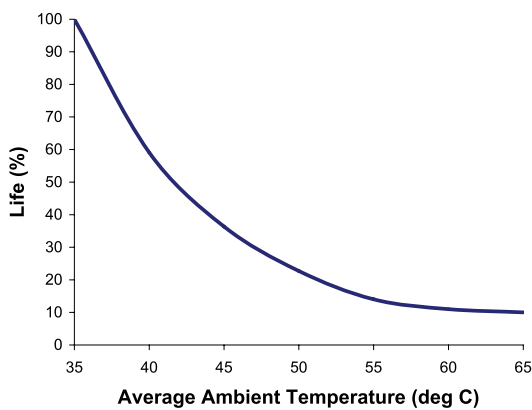

Change in capacitor life with respect to average ambient  
temperature (at constant voltage)

## Life Expectancy of Power Capacitors

### Rated voltage (Vn)

The Rated voltage of the capacitor shall be equal to (or) higher than the maximum network voltage with the power factor correction installation.

The preferred rated voltage of the unit or bank shall be 240V for single – phase and 440V for the three – phase system.

### Maximum permissible over voltage at Rated frequency (50Hz):

- 1.00 x Un - Continuous
- 1.10 x Un - up to 12 hrs per day
- 1.15 x Un - up to 30 min per day
- 1.20 x Un - 5 min
- 1.30 x Un - 1 min

### Maximum permissible current (I<sub>N</sub>)

Capacitor units shall be suitable for continuous operation at an rms current 1.30 times the current that occurs at rated sinusoidal voltage and rated frequency, excluding transients. Taking in to account the capacitance tolerances of 1.1C<sub>N</sub>, the maximum permissible current can be up to 1.43 I<sub>N</sub>. These over current factors are intended to take care of the combined effects of harmonics and over voltage up to and including 1.10 U<sub>N</sub>.

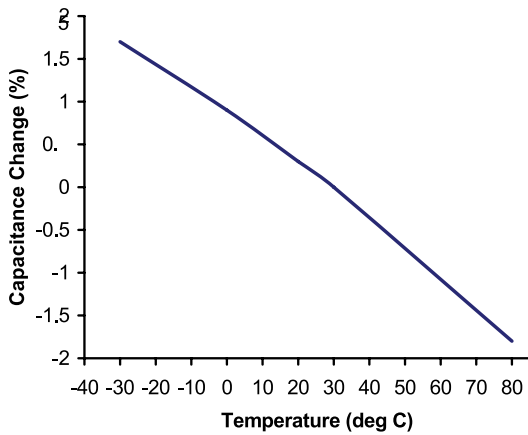

Change in capacitance with respect to Ambient temperature

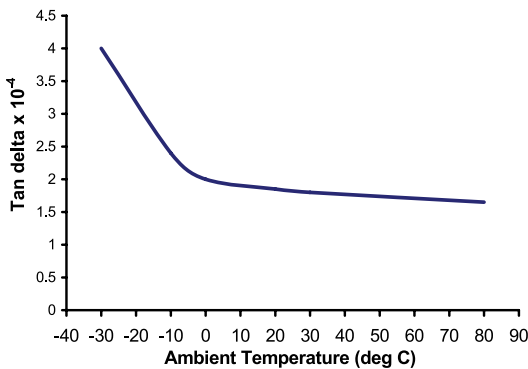

Change of Tan Delta (Loss Angle) with respect to Ambient temperature

### Maximum ambient temperature limit

Temperature Category	Maximum Ambient Air Temperature (°C)		
	Upper Limit	Highest Mean Temperature	
		For One Day	For One Year
A	40°	30°	20°
B	45°	35°	25°
C	50°	40°	30°
D	55°	45°	35°

Reference chart for temperature categories.

Note:

Ambient air temperatures can be increased by 5 C for indoor installations in enclosures

Please see 'Capacitor Life – Important Considerations' below as per the diagram indicated

### Variation In capacitance due to temperature variation

- a. At Lower Temp. Limit: ≤ 1%
- b. At Upper Temp. Limit: ≤ 1%



## Life expectancy of power capacitors

### Number of switching operations

The frequent switching on and off of capacitors places additional electrical stress on them due to the inrush current phenomena associated with capacitors. The inrush current magnitude depends upon the kVAR switched and the fault level at the point of capacitor switching. If the capacitors are switched very close to the secondary of the Transformer, then the inrush current is likely to be high as the fault level is high.

Every capacitor type has a peak inrush current rating expressed as multiples of rated current such as  $150 I_N$  to  $400 I_N$  depending upon capacitor duty.

A capacitor used in APFC application is subjected to frequent switching and hence should be selected to withstand high number of switching operations and capable of withstanding large inrush currents. The reliability of the capacitors used in APFC is proportional to the inrush current rating.

Following any one of techniques are used to reduce the inrush current drawn by capacitors thereby increasing the life of capacitors and associated switching devices.

1. Inrush current limiting coils in series with capacitors
2. Capacitor duty contactors
3. Thyristor switching devices

### Environmental factors

1. Capacitors are to be installed in dry & away from heat generating sources. It should be installed, ensuring cross ventilation for better heat conduction
2. For APFC panel application it is recommended to provided forced cooling fan.
3. Additional cooling provision should be made in APFC panels installed with reactors.

# Selection of Capacitor (kVAR & voltage) for Detuned Filter Application

LV - Power Quality Products  
& Solutions

Selection of Capacitor (kVAR & Voltage) for Detuned  
Filter Application

E-2



# Selection of capacitor (kVAr & voltage) for detuned filter application

In the Detuned filter application the voltage across the capacitors is higher than the nominal system voltage. And also the presence of series reactor will increase the voltage across the capacitor due to Ferranti effect. Therefore capacitors have been designed to withstand higher voltages.

The table provides the details of capacitor voltage applicable for different voltages

### Option 1

Tuning Factor P(%)	Detuning Frequency @50Hz	Tuning order (Fh/F1)	Network Voltage/ Reactor Voltage(Vs)	Capacitor Rated Voltage (Vn)
5.67%	210 Hz	4.2	440V	480V
7%	189 Hz	3.8	440V	480V
14%	134 H	2.67	440V	525V

### Option 2

Tuning Factor P(%)	Detuning Frequency @50Hz	Tuning order (Fh/F1)	Network Voltage/ Reactor Voltage(Vs)	Capacitor Rated Voltage (Vn)
5.67%	210 Hz	4.2	440V	525V
7%	189 Hz	3.8	440V	525V

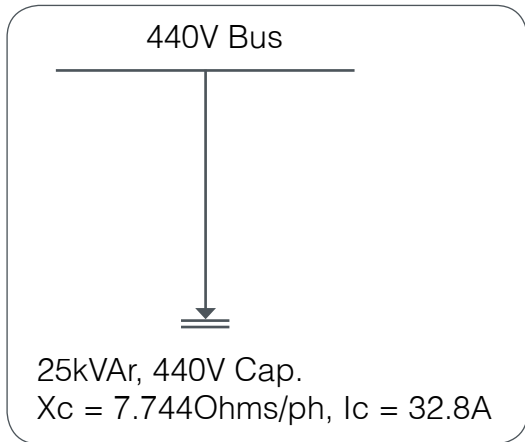

### Calculation for capacitor voltage & output in detuned filter application

#### Case – 1:

Assume a bus with a voltage of 440V, on which there is a 3ph capacitor of 25kVAr, 440V as shown below

The capacitor will draw a current as per the following formula:

$$I_c = \frac{\text{kVAr} \times 1000}{[\text{VL-L} \times (\sqrt{3})]}$$

$$= \frac{25 \times 1000}{(3 \times 440)}$$

$$= 32.8 \text{ Amps.}$$

The capacitive reactance of the capacitor  $X_c = \frac{V^2}{(\text{kVAr} \times 1000)}$   
 $X_c = 7.744 \text{ ohms / phase.}$

#### Case – 2:

Assume, we connect a Series reactor whose Inductive reactance is 7% of above capacitive reactance (i.e. 7% de-tuned reactor):

The effective reactance of the series L-C circuit will be;

$$X = +jX_L - jX_c$$

$$= +j0.5428 - j7.744$$

$$X = -j7.2\text{Ohms / phase.}$$

The current in the series LC circuit will be:

$$I_{c1} = \frac{\text{VL-L}}{(\sqrt{3} \times X)}$$

$$I_{c1} = \frac{440}{(\sqrt{3} \times 7.2)}$$

$$I_{c1} = 35.27 \text{ Amps.}$$

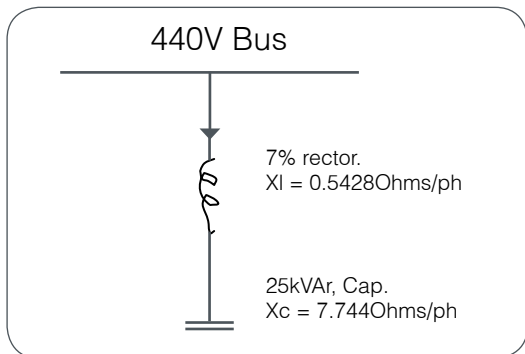

# Selection of capacitor (kVAr & voltage) for detuned filter application

## Effect of adding series reactor

### a) Capacitor voltage:

The presence of 7% reactor in series with the capacitor will increase the voltage across capacitor as per the following:

The capacitor voltage is given by:

$$V_c = \sqrt{3} \times I_{c1} \times X_c$$

$$V_c = \sqrt{3} \times 35.27 \times (-j)7.44 \text{ Volts.}$$

$$V_c = 473.11 \text{ Volts.}$$

$$V_{bus} = 440V.$$

$$\text{Increase in Capacitor voltage} = 7.5\% \text{ (on 440V)}$$

### b) Voltage across the reactor:

The reactor voltage is given by:

$$V_c = \sqrt{3} \times I_{c1} \times X_L$$

$$V_c = \sqrt{3} \times 35.27 \times (j)0.5428 \text{ Volts.}$$

$$V_c = 33.11 \text{ Volts.}$$

The capacitor will be subjected to 7.5% over voltage continuously, leading to premature failure. Consequently, the capacitor used in de-tuned filter application will be designed for higher voltage.

## Standard detuned filter configuration available

Sr. No.	Vsys Un	Effective Filter output kVAr (Qn)	P %	Capacitor details		Reactor details	
				kVAr (Qc)	V design (Uc)	XL @ 50Hz - Ohms	L - mH
1	440	25	7	27.7	480	0.583	1.855
2	440	25	7	33.1	525	0.583	1.855

### Formula used to calculate capacitor kVAr

$$\text{Capacitor kVAr} = (V_{\text{design}} / V_{\text{sys}})^2 \times \{ \text{Effective filter output in kVAr} \times (1 - p / 100) \}$$

$$Q_c = (U_c / U_n)^2 \times \{ Q_n \times [1 - P/100] \}.$$

### Example:

If the tuning factor  $P = 7\%$ .

Effective filter output  $Q_n = 25\text{kVAr}$ .

System voltage  $U_n = 440V$ .

Capacitor design voltage  $U_c = 480V$ .

Then the capacitor kVAr  $Q_c = (480/440)^2 \times [25 \times (1-7/100)]$

$$Q_c = 27.7\text{kVAr.}$$

Similarly we can calculate the design kVAr of capacitor for any other de-tuned filters such as 14% or 5.7%.

# Selection of capacitor (kVAr & voltage) for detuned filter application



Effective kVAr out put of Detuned Filter @440V	Selection of 480V capacitors for 7% / 5.7% detuned Filter for 440V
5	5kVAr 7% / 5.7% Reactor + 5.6 kVAr , 480V Capacitor
10	10 kVAr 7% / 5.7% Reacor + 11.3 kVAr,480V Capacitor
12.5	12.5 kVAr 7% / 5.7% Reactor + 14.4 kVAr, 480V Capacitor
15	15 kVAr 7% / 5.7% Reactor + 17 kVAr, 480V Capacitor
20	20 kVAr 7% / 5.7% Reactor + 22.4 kVAr , 480V Capacitor
25	25 kVAr 7% / 5.7% Reactor + 28.1 kVAr, 480V Capacitor
50	50 kVAr 7% / 5.7% Reactor + 2 x 28.1 kVAr, 480V Capacitor
75	75 kVAr 7% / 5.7% Reactor + 3 x 28.1 kVAr, 480V Capacitor
100	100 kVAr 7% / 5.7% Reactor + 4 x 28.1 kVAr, 480V Capacitor



Effective kVAr out put of Detuned Filter @440V	Selection of 525V capacitors for 7% / 5.7% detuned Filter for 440V
5	5kVAr 7% / 5.7% Reactor + 6.9 kVAr , 525V Capacitor
10	10 kVAr 7% / 5.7% Reacor + 13.8 kVAr,525V Capacitor
12.5	12.5 kVAr 7%/ 5.7% Reactor + 17.2 kVAr, 525V Capacitor
15	15 kVAr 7% / 5.7% Reactor + 20.6 kVAr, 525V Capacitor
20	20 kVAr 7% / 5.7% Reactor + 27.5 kVAr , 525V Capacitor
25	25 kVAr 7% / 5.7% Reactor + 33.1 kVAr, 525V Capacitor
50	50 kVAr 7% / 5.7% Reactor + 2 x 33.1 kVAr, 525V Capacitor
75	75 kVAr 7% / 5.7% Reactor + 3 x 33.1 kVAr, 525V Capacitor
100	100 kVAr 7% / 5.7% Reactor + 4 x 33.1 kVAr, 525V Capacitor

Effective kVAr out put of Detuned Filter @440V	Selection of 525V capacitors for 14% detuned Filter for 440V
5	5kVAr 14% Reactor + 6.9 kVAr, 525V Capacitor
10	10 kVAr 14% Reacor + 12.5 kVAr, 525V Capacitor
12.5	12.5 kVAr 14% Reactor + 15.4 kVAr, 525V Capacitor
15	15 kVAr 14% Reactor + 18.5 kVAr, 525V Capacitor
20	20 kVAr 14% Reactor + 25 kVAr, 525V Capacitor
25	25 kVAr 14% Reactor + 30.6 kVAr, 525V Capacitor
50	50 kVAr 14% Reactor + 2 x 30.6 kVAr, 525V Capacitor
75	75 kVAr 14% Reactor + 3 x 30.6 kVAr, 525V Capacitor
100	100 kVAr 14% Reactor + 4 x 30.6 kVAr, 525V Capacitor



# Low Voltage Capacitors

LV - Power Quality Products  
& Solutions

 EasyCan (SDuty)	F-2
 VarplusCan (HDuty)	F-4
 VarplusCan (GHDuty)	F-7
VarplusCan Mechanical Characteristics	F-10
VarplusBox Standard Duty	F-12
VarplusBox Heavy Duty	F-14
VarplusBox Energy, Ultra Heavy Duty(MD-XL)	F-17
VarplusBox Mechanical Characteristics	F-20



A safe, reliable and high-performance solution for power factor correction in standard operating conditions.



EasyCan (SDuty)

## Main features

### Easy installation & maintenance

- Optimized design for low weight, compactness and reliability to ensure easy installation.
- Unique termination system that allows maintained tightness.
- 1 point for mounting and earthing.
- Vertical position.

### Application parameters

- For networks with insignificant non-linear loads: ( $N_{LL} \leq 10\%$ ).
- Standard voltage disturbances.
- Standard operating temperature up to 55°C.
- Normal switching frequency up to 5000 / year.
- Maximum current (including harmonics) is  $1.5 \times I_N$ .

## Technology

Constructed internally with three single-phase capacitor elements assembled in an optimized design. Each capacitor element is manufactured with metallized polypropylene film as the dielectric having features such as heavy edge metallization and special profiles which enhance the “self-healing” properties.

The active capacitor elements are encapsulated in a specially formulated biodegradable, non-PCB, PUR (soft) resin which ensures thermal stability and heat removal from inside the capacitor.

The unique finger-proof CLAMPTITE termination is fully integrated with discharge resistors and allows suitable access to tightening and ensures cable termination without any loose connections.

Once tightened, the design guarantees that the tightening torque is always maintained.

For lower ratings, double fast-on terminals with wires are provided.

## Benefits

- Safety:
  - > Self-healing
  - > Pressure - sensitive disconnecter on all three phases
  - > Discharge resistor
- Life expectancy up to 100,000 hours.
- Economic benefits and easy installation due to its compact size and low weight.
- Easy maintenance thanks to its unique finger-proof termination to ensure tightening.
- Also available in small power ratings from 1 to 5 kVAR.

Technical specifications

General characteristics		
Standards	IS13340-1993, IS13341-1992	
Voltage range	440V	
Frequency	50Hz	
Power range	1 to 25 kVAr	
Losses (dielectric)	< 0.2W/kVAr	
Losses (total)	< 0.5W/kVAr	
Capacitance tolerance	-5%, +10%	
Voltage test	Between terminals	2.15 x U <sub>N</sub> (AC), 10s
	Between terminal & container	≤ 525V: 3kv(AC), 10s or 3.66kv(AC), 2s > 525V : 3.66kv(AC), 10s or 4.4kv(AC), 2s
	Impulse voltage	≤ 690V: 8 Kv
Discharge resistor	Fitted, standard discharge time 60s	
Operating conditions		
Ambient temperature	-25°C / +55°C (class D)	
Humidity	95 %	
Altitude	2,000 m above sea level	
Overvoltage	1.00 x U <sub>N</sub> - Continuous	
	1.10 x U <sub>N</sub> - up to 12 hrs per day	
	1.15 x U <sub>N</sub> - up to 30 min per day	
	1.20 x U <sub>N</sub> - 5 min	
	1.30 x U <sub>N</sub> - 1 min	
Overcurrent	Up to 1.5xI <sub>N</sub>	
Peak inrush current	200xI <sub>N</sub>	
Switching operations (max.)	Up to 5000 switching operations per year	
Mean Life expectancy	Up to 100,000 hrs	
Installation characteristics		
Mounting position	Indoor, upright	
Fastening	Threaded M12 stud at the bottom	
Earthing		
Terminals	CLAMPTITE - three-way terminal with electric shock protection (finger-proof) & double fast-on terminal in lower kVAr	
Safety features		
Safety	Self-healing + Pressure-sensitive disconnecter + Discharge device	
Protection	IP20	
Construction		
Casing	Extruded Aluminium Can	
Dielectric	Metallized polypropylene film with Zn/Al alloy	
Impregnation	Biodegradable, Non-PCB, PUR (soft) resin	

EasyCan (S Duty) 440V, 3 Phase, 50Hz								
50 Hz		Capacitance (3*mfd)	Reference Number	Dimention		Height h+t(mm)	Net Weight	Case Code
Q <sub>N</sub> (kVAr)	I <sub>N</sub> (Amps)			D(mm)	H(mm)			
1	1.3	5.5	MEHVCSY010A44	63	90	140	0.5	EC
2	2.6	11.0	MEHVCSY020A44	63	115	165	0.6	FC
3	3.9	16.4	MEHVCSY030A44	50	195	245	0.7	DC
4	5.2	21.9	MEHVCSY040A44	50	195	245	0.7	DC
5	6.6	27.4	MEHVCSY050A44	63	195	245	0.9	HC
7.5	9.8	41.1	MEHVCSY075A44	63	195	245	0.9	HC
10	13.1	54.8	MEHVCSY100A44	70	195	245	1.1	LC
12.5	16.4	68.5	MEHVCSY125A44	75	278	308	1.2	NC
15	19.4	82.2	MEHVCSY150A44	75	278	308	1.2	NC
20	26.2	109.7	MEHVCSY200A44	90	278	308	2.3	SC
25	32.8	137.1	MEHVCSY250A44	90	278	308	2.4	SC

A safe, reliable and high-performance solution for power factor correction in heavy-duty operating conditions.



VarplusCan HDuty



50 kVAR unit, 440V

### Main features

#### Easy installation & maintenance

- Optimized design for low weight, compactness and reliability to ensure easy installation.
- Unique termination system that allows maintained tightness.
- 1 point for mounting and earthing.
- Vertical and horizontal position.

#### Application parameters

- For networks with insignificant non-linear loads: ( $N_{LL} < 20\%$ ).
- Significant voltage disturbances.
- Standard operating temperature up to 55°C.
- Normal switching frequency up to 7000 /year.
- Maximum current (including harmonics) is  $1.8 \times I_N$ .

#### Technology

Constructed internally with three single-phase capacitor elements. Each capacitor element is manufactured with metallized polypropylene film as the dielectric, having features such as heavy edge, slope metallization and wave-cut profile to ensure increased current handling capacity and reduced temperature rise.

The active capacitor elements are coated with specially formulated sticky resin which ensures high overload capabilities and good thermal and mechanical properties

The unique finger-proof CLAMPTITE termination is fully integrated with discharge resistors, allowing suitable access for tightening and ensuring cable termination without any loose connections.

For lower ratings, double fast-on terminals with wires are provided.

#### Benefits

- Total safety:
  - > Self - healing
  - > Pressure- sensitive disconnecter
  - > Discharge resistor
- Long life expectancy (up to 130,000 hours).
- Installation in any position vertical or horizontal
- Optimized geometric design for improved thermal performance.
- Special resistivity and metallisation profile will enhance life and will give higher thermal efficiency with lower temperature rise.
- Unique finger-proof termination that ensures tightening for CLAMPITE terminals.

#### Terminal Unique Features

CLAMPITE (IP20): Three phase terminal with electric shock protection (finger proof) up to 30kVAR unit

- Termination is designed for cable entry of cross section minimum 2.5 sq mm, maximum 16 sq mm
- This unique clampite design enables the use of cables without lugs. Which ensures better termination and avoids loose connection.
- **STUD type (IP00):** Three phase terminal provided for better current handling capabilities (for 40kVAR & 50kVAR units, 440V)
- Termination is designed for cable entry of cross section 35 sq mm for higher kVAR ratings

Technical specifications

General characteristics		
Standards		IS3340 - 1993, IS13341 - 1992, IEC 60831-1/-2
Voltage range		440V, 480V, 525V
Frequency		50Hz
Power range		1 to 50 kVAr
Losses (dielectric)		< 0.2W/kVAr
Losses (total)		< 0.5W/kVAr
Capacitance tolerance		-5%, +10%
Voltage test	Between terminals	2.15 x U <sub>N</sub> (AC), 10s
	Between terminal & container	≤ 525 V: 3 kV (AC), 10 s or 3.66 kV (AC), 2 s > 525 V: 3.66 kV (AC), 10 s or 4.4 kV (AC), 2 s
	Impulse voltage	≤ 690 V: 8 kV
Discharge resistor		Fitted, standard discharge time 60s
Ambient temperature		-25°C / +55°C (Class D)
Humidity		95 %
Altitude		2,000 m above sea level
Overvoltage		1.00 x U <sub>n</sub> - Continuous
		1.10 x U <sub>n</sub> - up to 12 hrs per day
		1.15 x U <sub>n</sub> - up to 30 min per day
		1.20 x U <sub>n</sub> - 5 min
		1.30 x U <sub>n</sub> - 1 min
Overcurrent		Up to 1.8xI <sub>N</sub>
Peak inrush current		250 x I <sub>N</sub>
Switching operations (max.)		Up to 7000 switching operations per year
Mean Life expectancy		Up to 130,000 hrs
Installation characteristics		
Mounting position		Indoor, upright & horizontal
Fastening		Threaded M12 stud at the bottom
Earthing		
Terminals		CLAMPTITE - three-way terminal with electric shock protection (finger-proof) & double fast-on terminal in lower kVAr
Safety features		
Safety		Self-healing + Pressure-sensitive disconnecter + Discharge device
Protection		IP20
Construction		
Casing		Extruded Aluminium Can
Dielectric		Metallized polypropylene film with Zn/Al alloy. Special resistivity & profile, special edge (wave-cut)
Impregnation		Non-PCB, PUR sticky resin (Dry)

Varplus Can Heavy Duty (H Duty), 440V, 3 Phase, 50Hz								
50 Hz		Capacitance (3*mfd)	Reference Number	Dimention		Height h+t(mm)	Net Weight	Case Code
Q <sub>N</sub> (kVAR)	I <sub>N</sub> (Amps)			D(mm)	H(mm)			
1	1.3	5.5	MEHVCHDY010A44	63	90	140	0.5	EC
2	2.6	11	MEHVCHDY020A44	50	195	245	0.6	DC
3	3.9	16.4	MEHVCHDY030A44	50	195	245	0.6	DC
4	5.2	21.9	MEHVCHDY040A44	50	195	245	0.7	DC
5	6.6	27.4	MEHVCHDY050A44	63	195	245	0.8	HC
7.5	9.8	41.1	MEHVCHDY075A44	63	195	245	0.9	HC
10	13.1	54.8	MEHVCHDY100A44	75	203	233	1.5	MC
12.5	16.4	68.5	MEHVCHDY125A44	90	212	242	1.6	RC
15	19.7	82.2	MEHVCHDY150A44	90	212	242	1.6	RC
20	26.2	109.7	MEHVCHDY200A44	116	212	242	2.5	TC
25	32.8	137.1	MEHVCHDY250A44	116	212	242	2.5	TC
30	39.4	164.5	MEHVCHDY300A44	136	212	242	3.2	VC
40	52.5	219.3	MEHVCHDY400A44	116	278	321	4.1	XC
50	65.6	274.2	MEHVCHDY500A44	136	278	321	5.3	YC

480V Capacitors for 5.7% / 7% detuned filter application								
Varplus Can Heavy Duty (H Duty), 480V, 3 Phae, 50Hz								
50 Hz		Capacitance (3*mfd)	Reference Number	Dimention		Height h+t(mm)	Net Weight	Case Code
Q <sub>N</sub> (kVAR)	I <sub>N</sub> (Amps)			D(mm)	H(mm)			
5.6	6.7	25.8	MEHVCHDY056A48	63	195	245	0.9	HC
6.7	8.1	30.9	MEHVCHDY067A48	63	195	245	0.9	HC
11.3	13.6	52.1	MEHVCHDY113A48	75	203	233	1.2	MC
12.5	15.0	57.6	MEHVCHDY125A48	90	212	242	1.6	RC
14.4	17.3	66.3	MEHVCHDY144A48	90	212	242	1.6	RC
15.5	18.6	71.4	MEHVCHDY155A48	90	212	242	1.6	RC
17	20.4	78.3	MEHVCHDY170A48	90	212	242	1.6	RC
19	22.9	87.5	MEHVCHDY190A48	116	212	242	2.5	TC
22.4	26.9	103.2	MEHVCHDY224A48	116	212	242	2.5	TC
25	30.1	115.2	MEHVCHDY250A48	116	212	242	2.5	TC
28.1	33.8	129.5	MEHVCHDY281A48	136	212	242	3.2	VC
31.5	37.9	145.1	MEHVCHDY315A48	136	212	242	3.2	VC

525V Capacitors for 5.67%, 7% & 14% detuned filter Application								
Varplus Can Heavy Duty (H Duty), 525V, 3 Phase, 50Hz								
50 Hz		Capacitance (3*mfd)	Reference Number	Dimention		Height h+t(mm)	Net Weight	Case Code
Q <sub>N</sub> (kVAR)	I <sub>N</sub> (Amps)			D(mm)	H(mm)			
6.9	7.6	26.6	MEHVCHDY069A52	63	195	245	0.9	HC
12.5	13.7	48.1	MEHVCHDY125A52	90	212	242	1.6	RC
13.8	15.2	53.2	MEHVCHDY138A52	90	212	242	1.6	RC
15.4	16.9	59.3	MEHVCHDY154A52	90	212	242	1.6	RC
17.2	18.9	66.2	MEHVCHDY172A52	90	212	242	1.6	RC
18.5	20.3	71.3	MEHVCHDY185A52	116	212	242	2.5	TC
20.6	22.7	79.3	MEHVCHDY206A52	116	212	242	2.5	TC
22.6	24.9	87.0	MEHVCHDY226A52	116	212	242	2.5	TC
25	27.5	96.3	MEHVCHDY250A52	116	212	242	2.5	TC
27.5	30.2	105.9	MEHVCHDY275A52	116	212	242	2.5	TC
30.6	33.7	117.9	MEHVCHDY306A52	136	212	242	3.2	VC
33.1	36.4	127.5	MEHVCHDY331A52	136	212	242	3.2	VC
34.4	37.8	132.5	MEHVCHDY344A52	136	212	242	3.2	VC
37.7	41.5	145.2	MEHVCHDY377A52	136	212	242	3.2	VC

A safe, reliable and high-performance solution for power factor correction in heavy-duty operating conditions.



Varplus Can GH Duty

**Main features**

**Easy installation & maintenance**

- Optimized design for low weight, compactness and reliability to ensure easy installation.
- Unique termination system that allows maintained tightness.
- 1 point for mounting and earthing.
- Vertical and horizontal position.

**Application parameters**

- For networks with insignificant non-linear loads: ( $N_{LL} < 20\%$ ).
- Significant voltage disturbances.
- Standard operating temperature up to 55°C.
- Normal switching frequency up to 7000 /year.
- Maximum current (including harmonics) is  $1.8 \times I_N$ .

**Technology**

Constructed internally with three single-phase capacitor elements. Each capacitor element is manufactured with metallized polypropylene film as the dielectric, having features such as heavy edge, slope metallization and wave-cut profile to ensure increased current handling capacity and reduced temperature rise.

The active capacitor elements are coated with specially formulated sticky resin which ensures high overload capabilities and good thermal and mechanical properties

- α Dielectric: Polypropylene film
- α Gas - impregnated, dry type, non-PCB
- α Wave cut

The unique finger-proof CLAMP TITE termination is fully integrated with discharge resistors, allowing suitable access for tightening and ensuring cable termination without any loose connections.

For lower ratings, double fast-on terminals with wires are provided.

**Benefits**

- Total safety:
  - > Self - healing
  - > Pressure- sensitive disconnecter
  - > Discharge resistor
- Long life expectancy (up to 130,000 hours).
- Installation in any position.
- Optimized geometric design for improved thermal performance.
- Special resistivity and metallisation profile will enhance life and will give higher thermal efficiency with lower temperature rise.
- Unique finger-proof termination that ensures tightening for CLAMP TITE terminals.

**Terminal unique features**

CLAMP TITE (IP20): Three phase terminal with electric shock protection (finger proof) up to 30kVAR unit

- Termination is designed for cable entry of cross section minimum 2.5 sq mm, maximum 16 sq mm
- This unique clamp tite design enables the use of cables without lugs. Which ensure better termination and avoid loose connection.
- **STUD type (IP00):** Three phase terminal provided for better current handling capabilities (for 40kVAR & 50kVAR units, 440V)
- Termination is designed for cable entry of cross section 35 sq mm for higher kVAR ratings



50 kVAR unit, 440V

## Technical specifications

General characteristics		
Standards		IS3340 - 1993, IS13341 - 1992, IEC 60831-1/-2
Voltage range		440V, 480V, 525V
Frequency		50Hz
Power range		5 kVAr to 50 kVAr
Losses (dielectric)		< 0.2W/kVAr
Losses (total)		< 0.5W/kVAr
Capacitance tolerance		-5%, +10%
Voltage test	Between terminals	$2.15 \times U_N$ (AC), 10 s
	Between terminal & container	$\leq 525$ V: 3 kV (AC), 10 s or 3.66 kV (AC), 2 s $> 525$ V: 3.66 kV (AC), 10 s or 4.4 kV (AC), 2 s
	Impulse voltage	$\leq 690$ V: 8 kV
Discharge resistor		Fitted, standard discharge time 60 s
Ambient temperature		-25°C / +55°C (Class D)
Humidity		95%
Altitude		2,000 m above sea level
Overvoltage		1.00 x $U_N$ - Continuous
		1.10 x $U_N$ - up to 12 hrs per day
		1.15 x $U_N$ - up to 30 min per day
		1.20 x $U_N$ - 5 min
		1.30 x $U_N$ - 1 min
Overcurrent		Up to $1.8 \times I_N$
Peak inrush current		$250 \times I_N$
Switching operations (max.)		Up to 7000 switching operations per year
Mean Life expectancy		Up to 130,000 hrs
Installation characteristics		
Mounting position		Indoor, upright & horizontal
Fastening		Threaded M12 stud at the bottom
Earthing		
Terminals		CLAMPTITE - three-way terminal with electric shock protection (finger-proof) & double fast-on terminal in lower kVAr
Safety features		
Safety		Self-healing + Pressure-sensitive disconnecter + Discharge device
Protection		IP20
Construction		
Casing		Extruded Aluminium Can
Dielectric		Metallized polypropylene film with Zn/Al alloy. Special resistivity & profile, special edge (wave-cut)
Impregnation		Gas - impregnated, dry type, non-PCB



Varplus Can Gas Heavy Duty (GH Duty) Dry 440V, 3 Phase, 50Hz								
50 Hz		Capacitance (3*mfd)	Reference Number	Dimention		Height h+t(mm)	Net Weight	Case Code
Q <sub>N</sub> (kVAR)	I <sub>N</sub> (Amps)			D(mm)	H(mm)			
5	6.6	27.4	MEHVCGSF050A44	63	195	245	0.8	HC
7.5	9.8	41.1	MEHVCGSF075A44	63	195	245	0.9	HC
10	13.1	54.8	MEHVCGSF100A44	75	203	233	0.9	MC
12.5	16.4	68.5	MEHVCGSF125A44	90	212	242	1.6	RC
15	19.4	82.2	MEHVCGSF150A44	90	212	242	1.6	RC
20	26.2	109.7	MEHVCGSF200A44	116	212	242	2.5	TC
25	32.8	137.1	MEHVCGSF250A44	116	212	242	2.5	TC
30	39.4	164.5	MEHVCGSF300A44	136	212	242	3.2	VC
40	52.5	219.3	MEHVCGSF400A44	116	278	321	4.1	XC
50	65.6	274.2	MEHVCGSF500A44	136	278	321	5.3	YC

480V Capacitors for 5.7% / 7% Detuned filter application								
Varplus Can Gas Heavy Duty (GH Duty), 480V, 3 Phase, 50Hz								
50 Hz		Capacitance (3*mfd)	Reference Number	Dimention		Height h+t(mm)	Net Weight	Case Code
Q <sub>N</sub> (kVAR)	I <sub>N</sub> (Amps)			D(mm)	H(mm)			
5.6	6.7	25.8	MEHVCGSF056A48	63	195	245	0.9	HC
6.7	8.1	30.9	MEHVCGSF067A48	63	195	245	0.9	HC
11.3	13.6	52.1	MEHVCGSF113A48	75	203	233	1.2	MC
12.5	15.0	57.6	MEHVCGSF125A48	90	212	242	1.6	RC
14.4	17.3	66.3	MEHVCGSF144A48	90	212	242	1.6	RC
15.5	18.6	71.4	MEHVCGSF155A48	90	212	242	1.6	RC
17	20.4	78.3	MEHVCGSF170A48	90	212	242	1.6	RC
19	22.9	87.5	MEHVCGSF190A48	116	212	242	2.5	TC
22.4	26.9	103.2	MEHVCGSF224A48	116	212	242	2.5	TC
25	30.1	115.2	MEHVCGSF250A48	116	212	242	2.5	TC
28.1	33.8	129.5	MEHVCGSF281A48	136	212	242	3.2	VC
31.5	37.9	145.1	MEHVCGSF315A48	136	212	242	3.2	VC

525V Capacitors for 5.67%, 7% / 14% Detuned filter application								
Varplus Can Gas Heavy Duty (GH Duty), 525V, 3 Phase, 50Hz								
50 Hz		Capacitance (3*mfd)	Reference Number	Dimention		Height h+t(mm)	Net Weight	Case Code
Q <sub>N</sub> (kVAR)	I <sub>N</sub> (Amps)			D(mm)	H(mm)			
6.9	7.6	26.6	MEHVCGSF069A52	63	195	245	0.9	HC
12.5	13.7	48.1	MEHVCGSF125A52	90	212	242	1.6	RC
13.8	15.2	53.2	MEHVCGSF138A52	90	212	242	1.6	RC
15.4	16.9	59.3	MEHVCGSF154A52	90	212	242	1.6	RC
17.2	18.9	66.2	MEHVCGSF172A52	90	212	242	1.6	RC
18.5	20.3	71.3	MEHVCGSF185A52	116	212	242	2.5	TC
20.6	22.7	79.3	MEHVCGSF206A52	116	212	242	2.5	TC
22.6	24.9	87.0	MEHVCGSF226A52	116	212	242	2.5	TC
25	27.5	96.3	MEHVCGSF250A52	116	212	242	2.5	TC
27.5	30.2	105.9	MEHVCGSF275A52	116	212	242	2.5	TC
30.6	33.7	117.9	MEHVCGSF306A52	136	212	242	3.2	VC
33.1	36.4	127.5	MEHVCGSF331A52	136	212	242	3.2	VC
34.4	37.8	132.5	MEHVCGSF344A52	136	212	242	3.2	VC
37.7	41.5	145.2	MEHVCGSF377A52	136	212	242	3.2	VC

# VarplusCan mechanical characteristics

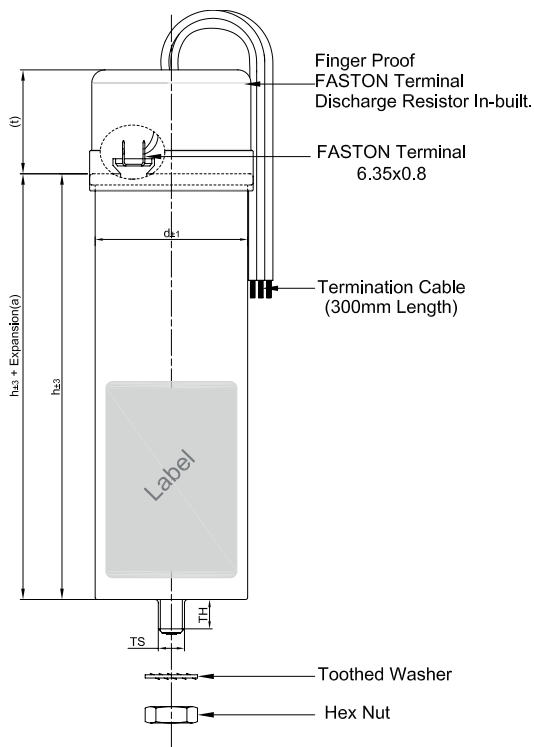

EasyCan DC, EC, FC, HC & LC.

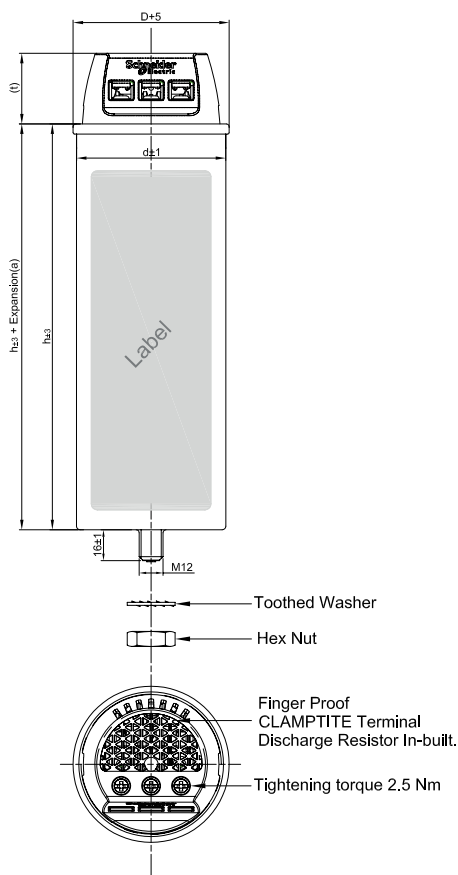

VarplusCan MC & RC

Case Code: DC,HC,FC,EC & LC				
Creepage distance	min. 16 mm			
Clearance	min. 16 mm			
Expansion (a)	max. 10 mm			
Mounting details (for M10/M12 mounting stud)				
Torque	M10: 7 N.m M12: 10 N.m			
Toothed washer	M10/M12			
Hex nut	M10/M12			
Terminal assembly Ht. (t)	50 mm			
Size (d)	TS	TH		
Ø 50	M10	10 mm		
Ø 63	M12	13 mm		
Ø 70	M12	16 mm		
Case code	Diameter d (mm)	Height h (mm)	Height h + t (mm)	Weight (kg)
DC	50	195	245	0.7
EC	63	90	140	0.5
FC	63	115	165	0.5
HC	63	195	245	0.9
LC	70	195	245	1.1

Case Code: MC & RC				
Creepage distance	min. 13 mm			
Clearance	min. 13 mm			
Expansion (a)	max. 12 mm			
Mounting details (for M12 mounting stud)				
Torque	T = 10 Nm			
Toothed washer	J12.5 DIN 6797			
Hex nut	BM12 DIN 439			
Terminal screw	M5			
Terminal assembly Ht. (t)	33 mm			
Case code	Diameter d (mm)	Height h (mm)	Height h + t (mm)	Weight (kg)
MC	75	203	233	1.2
RC	90	212	242	1.6

# VarplusCan mechanical characteristics

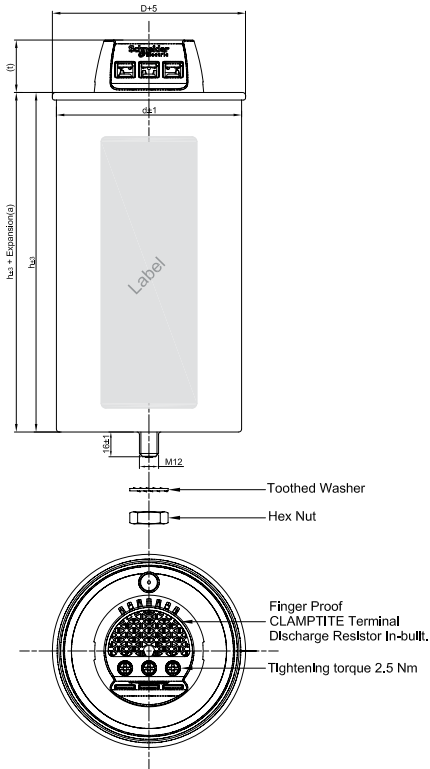

VarplusCan TC & VC.

Case Code: TC & VC				
Creepage distance	min. 13 mm			
Clearance	min. 13 mm			
Expansion (a)	max. 12 mm			
Mounting details (for M12 mounting stud)				
Torque	T = 10 Nm			
Toothed washer	J12.5 DIN 6797			
Hex nut	BM12 DIN 439			
Terminal screw	M5			
Terminal assembly Ht. (t)	33 mm			
Case code	Diameter d (mm)	Height h (mm)	Height h + t (mm)	Weight (kg)
TC	116	212	242	2.5
VC	136	212	242	3.2

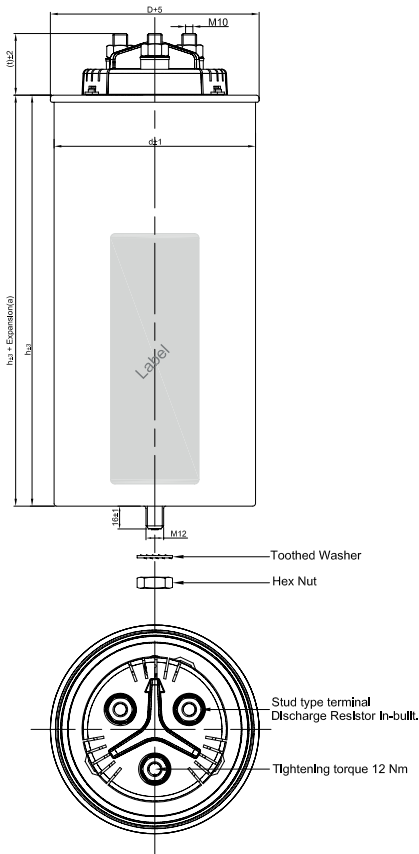

VarplusCan XC & YC.

Case Code: XC & YC				
Creepage distance	min. 13 mm			
Clearance	34 mm			
Expansion (a)	max. 17 mm			
Mounting details (for M12 mounting stud)				
Torque	T = 10 Nm			
Toothed washer	J12.5 DIN 6797			
Hex nut	BM12 DIN 439			
Terminal screw	M10			
Terminal assembly Ht. (t)	43 mm			
Case code	Diameter d (mm)	Height h (mm)	Height h + t (mm)	Weight (kg)
XC	116	278	321	4.1
YC	136	278	321	5.3

A safe, reliable and high-performance solution for power factor correction in standard operating conditions.



*VarplusBox SDuty*

## Main features

### Robustness

- Double metallic protection.  
Mechanically well suited for “stand-alone” installations.

### Application parameters

- For networks with insignificant non-linear loads ( $N_{LL} \leq 10\%$ ).
- Standard voltage disturbances.
- Standard operating temperature up to 55°C.
- Normal switching frequency up to 5000 /year.
- Maximum current withstand  $1.5 \times I_N$ .

### Technology

Constructed internally with three single-phase capacitor elements to form a three phase delta connected capacitor.

The design is specially adapted for mechanical stability. The enclosures of the units are designed to ensure that the capacitors operate reliably in hot and humid tropical conditions, without the need of any additional ventilation or louvres (see technical specifications).

Special attention is paid to equalization of temperatures within the capacitor enclosures since this gives better overall performance.

### Benefits

- Mechanically well suited for “stand-alone” installations.
- Safety:
  - > Self - healing
  - > Pressure - sensitive disconnecter on all three phases.
  - > Discharge resistor
- These capacitors can be easily mounted inside panels or in a stand-alone configuration.
- Availability on power ratings up to 50 kVAr.
- Suitable for flexible banking.

Technical specifications

General characteristics		
Standards	IEC 60831-1/-2, IS 13340-1993/ IS 13341-1992	
Voltage range	440V	
Frequency	50 / 60 Hz	
Power range	7.5 to 50 kVAr	
Losses (dielectric)	< 0.2W/kVAr	
Losses (total)	< 0.5W/kVAr	
Capacitance tolerance	-5%, +10%	
Voltage test	Between terminals	2.15 x U <sub>N</sub> (AC), 10 s
	Between terminal & container	≤ 525V: 3kv(AC), 10s or 3.66kv(AC), 2s > 525V : 3.66kv(AC), 10s or 4.4kv(AC), 2s
	Impulse voltage	≤ 690V : 8kv
Discharge resistor	Fitted, standard discharge time 60s Discharge time	
Ambient temperature	-25°C / +55°C (Class D)	
Humidity	95%	
Altitude	2,000 m above sea level	
Overvoltage	1.00 x U <sub>N</sub> - Continuous	
	1.10 x U <sub>N</sub> - up to 12 hrs per day	
	1.15 x U <sub>N</sub> - up to 30 min per day	
	1.30 x U <sub>N</sub> - 1 min	
	1.20 x U <sub>N</sub> - 5 min	
Overcurrent	Up to 1.5 x I <sub>N</sub>	
Peak inrush current	200 x I <sub>N</sub>	
Switching operations (max.)	Up to 5000 switching operations per year	
Mean Life expectancy	Up to 100,000 hrs	
Installation characteristics		
Mounting position	Indoor, upright	
Fastening	Mounting cleats	
Earthing		
Terminals	Bushing terminals designed for large cable termination and direct busbar mounting for banking	
Safety features		
Safety	Self-healing + Pressure-sensitive disconnecter for each phase + Discharge device	
Protection	IP20	
Construction		
Casing	Sheet steel enclosure	
Dielectric	Metallized polypropylene film with Zn/Al alloy.	
Impregnation	Biodegradable, Non-PCB, PUR (soft) resin	

Varplus BOX Standard Duty (S Duty) 440V, 3 Phase, 50Hz										
50 Hz		Capacitance (3*mfd)	Reference Number	Dimention					Net Weight (kg)	Case Code
Q <sub>N</sub> (kVAr)	I <sub>N</sub> (Amps)			W1(mm)	W2(mm)	W3(mm)	H(mm)	D(mm)		
7.5	9.8	41.1	MEHVBSDY075A44	263	243	213	260	97	3.6	EB
10	13.1	54.8	MEHVBSDY100A44	263	243	213	260	97	3.6	EB
12.5	16.4	68.5	MEHVBSDY125A44	263	243	213	260	97	3.6	EB
15	19.7	82.2	MEHVBSDY150A44	263	243	213	355	97	4.8	DB
20	26.2	109.7	MEHVBSDY200A44	263	243	213	355	97	4.8	DB
25	32.8	137.1	MEHVBSDY250A44	263	243	213	355	97	48	DB
30	39.4	164.5	MEHVBSDY300A44	309	289	259	455	153	8	HB
50	65.6	274.5	MEHVBSDY500A44	309	289	259	455	153	8	HB

A safe, reliable and high-performance solution for power factor correction in standard operating conditions.



VarplusBox HDuty

50 kVAr unit

## Main features

### Robustness

- Double metallic protection.  
Mechanically well suited for "stand-alone" installations.

### Application parameters

- For networks with significant non-linear loads ( $N_{LL} \leq 20\%$ ).
- Standard voltage disturbances.
- Standard operating temperature up to 55°C.
- Significant number of switching operations up to 7000/year.
- Long life expectancy up to 130,000 hours.

### Technology

Constructed internally with three single-phase capacitor elements.

The design is specially adapted for mechanical stability. The enclosures of the units are designed to ensure that the capacitors operate reliably in hot and humid tropical conditions, without the need of any additional ventilation or louvres (see technical specifications).

Special attention is paid to equalization of temperatures within the capacitor enclosures since this gives better overall performance.

### Benefits

- High performance:
  - > Heavy edge metallization/wave-cut edge to ensure high inrush current capabilities
  - > Special resistivity and profile metallization for better self-healing & enhanced life.
- Safety:
  - > Its unique safety feature electrically disconnects the capacitors safely at the end of their useful life
  - > The disconnectors are installed on each phase, which makes the capacitors very safe, in addition to its protective steel enclosure.
- Flexibility:
  - > Special «Compact» case with small footprint to be easily mounted and assembled
  - > Availability on power ratings up to 50 kVAr

## Technical specifications

General characteristics		
Standards		IEC 60831-1/-2, IS 13340-1993/ IS 13341-1992
Voltage range		440V, 480V, 525V
Frequency		50 / 60 Hz
Power range		5 to 50 kVAr
Losses (dielectric)		< 0.2W/kVAr
Losses (total)		< 0.5W/kVAr
Capacitance tolerance		-5 %, +10 %
Voltage test	Between terminals	$2.15 \times U_N$ (AC), 10s
	Between terminal & container	$\leq 525V$ : 3kv(AC),10s or 3.66kv(AC), 2s $> 525V$ : 3.66kv(AC), 10s or 4.4kv(AC),2s
	Impulse voltage	$\leq 690 V$ : 8 kV
Discharge resistor		Fitted, standard discharge time 60s
Ambient temperature		-25°C / 55°C (Class D)
Humidity		95 %
Altitude		2,000 m above sea level
Overvoltage		$1.00 \times U_N$ - Continuous
		$1.10 \times U_N$ - up to 12 hrs per day
		$1.15 \times U_N$ - up to 30 min per day
		$1.20 \times U_N$ - 5 min
		$1.30 \times U_N$ - 1 min
Overcurrent		Up to $1.8 \times I_N$
Peak inrush current		$250 \times I_N$
Switching operations (max.)		Up to 7000 switching operations per year
Mean Life expectancy		Up to 130,000 hrs
Installation characteristics		
Mounting position		Indoor, upright & horizontal
Fastening		Mounting cleats
Earthing		
Terminals		Bushing terminals designed for large cable termination and direct busbar mounting for banking
Safety features		
Safety		Self-healing + Pressure-sensitive disconnecter for each phase + Discharge device
Protection		IP20
Construction		
Casing		Sheet steel enclosure
Dielectric		Metallized polypropylene film with Zn/Al alloy. special resistivity & profile. Special edge (wave-cut)
Impregnation		Non-PCB, PUR sticky resin (Dry)

Varplus BOX Heavy Duty (H Duty) 440V, 3 phase, 50Hz										
50 Hz		Capacitance (3*mfd)	Reference Number	Dimention					Net Weight (kg)	Case Code
Q <sub>N</sub> (kVAr)	I <sub>N</sub> (Amps)			W1(mm)	W2(mm)	W3(mm)	H(mm)	D(mm)		
5	6.6	27.4	MEHVBHDY050A44	263	243	213	260	97	3.6	EB
7.5	9.8	41.1	MEHVBHDY075A44	263	243	213	260	97	3.6	EB
10	13.1	54.8	MEHVBHDY100A44	263	243	213	355	97	4.8	DB
12.5	16.4	68.5	MEHVBHDY125A44	263	243	213	355	97	4.8	DB
15	19.7	82.2	MEHVBHDY150A44	309	289	259	355	153	7.5	GB
20	26.2	109.7	MEHVBHDY200A44	309	289	259	355	153	7.5	GB
25	32.8	137.1	MEHVBHDY250A44	309	289	259	355	153	7.5	GB
30	39.4	164.5	MEHVBHDY300A44	309	289	259	497	224	10	IB
50	65.6	274.2	MEHVBHDY500A44	309	289	259	497	224	10	IB

480V Capacitors for 5.7% / 7% Detuned filter application										
Varplus Box Heavy Duty (H Duty), 480V, 3 Phase, 50Hz										
50 Hz		Capacitance (3*mfd)	Reference Number	Dimention					Net Weight (kg)	Case Code
Q <sub>N</sub> (kVAr)	I <sub>N</sub> (Amps)			W1(mm)	W2(mm)	W3(mm)	H(mm)	D(mm)		
5.6	6.7	25.8	MEHVBHDY056A48	263	243	213	260	97	3.6	EB
6.7	8.1	30.9	MEHVBHDY067A48	263	243	213	260	97	3.6	EB
11.3	13.6	52.1	MEHVBHDY113A48	263	243	213	355	97	3.6	DB
14.4	17.3	66.3	MEHVBHDY144A48	263	243	213	355	97	4.8	DB
17	20.4	78.3	MEHVBHDY170A48	309	289	259	355	153	7.5	GB
22.4	26.9	103.2	MEHVBHDY224A48	309	289	259	355	153	7.5	GB
25	30.1	115.2	MEHVBHDY250A48	309	289	259	355	153	7.5	GB
28.1	33.8	129.5	MEHVBHDY281A48	309	289	259	355	153	7.5	GB
31.5	37.9	145.1	MEHVBHDY315A48	309	289	259	355	153	7.5	GB
56.1	67.5	258.5	MEHVBHDY561A48	309	289	259	497	224	10	IB

525V Capacitors for 5.7% / 7% / 14% Detuned filter application										
Varplus Box Heavy Duty (H Duty), 525V, 3 Phase, 50Hz										
50 Hz		Capacitance (3*mfd)	Reference Number	Dimention					Net Weight (kg)	Case Code
Q <sub>N</sub> (kVAr)	I <sub>N</sub> (Amps)			W1 (mm)	W2 (mm)	W3 (mm)	H (mm)	D (mm)		
6.9	7.6	26.6	MEHVBHDY069A52	263	243	213	260	97	3.6	EB
12.5	13.7	48.1	MEHVBHDY125A52	263	243	213	355	97	4.8	DB
13.8	15.2	53.2	MEHVBHDY138A52	263	243	213	355	97	4.8	DB
15.4	16.9	59.3	MEHVBHDY154A52	263	243	213	355	97	4.8	DB
17.2	18.9	66.2	MEHVBHDY172A52	309	289	259	355	153	7.5	GB
18.5	20.3	71.3	MEHVBHDY185A52	309	289	259	355	153	7.5	GB
20.6	22.7	79.3	MEHVBHDY206A52	309	289	259	355	153	7.5	GB
22.6	24.9	87.0	MEHVBHDY226A52	309	289	259	355	153	7.5	GB
25	27.5	96.3	MEHVBHDY250A52	309	289	259	355	153	7.5	GB
27.5	30.2	105.9	MEHVBHDY275A52	309	289	259	355	153	7.5	GB
30.6	33.7	117.9	MEHVBHDY306A52	309	289	259	355	153	7.5	GB
33.1	36.4	127.5	MEHVBHDY331A52	309	289	259	355	153	7.5	GB
37.7	41.5	145.2	MEHVBHDY377A52	309	289	259	355	153	7.5	GB



# VarplusBox energy, ultra heavy duty (MD-XL)

A safe, reliable and high-performance solution for power factor correction in standard operating conditions.



VarplusBox Energy

## Main features

### Robustness

- Double metallic protection.
- Mechanically well suited for “stand-alone” installations.

### Application parameters

- For networks with significant non-linear loads: (NLL < 25 %).
- Severe voltage disturbances.
- Highest operating temperature (up to 70°C).
- High switching frequency, up to 10,000/year
- Maximum current withstand  $2.5 \times I_N$ .

### Technology

The Energy capacitor employs Metalized Polypropylene as the core, and for efficient heat dissipation double side metalized Kraft Paper (or hazy paper) is used. The conducting part of the metalized paper is short circuited to ensure that the metalized Paper is electrically isolated to keep the  $\tan(\delta)$  losses to the minimum.

The complete element of the capacitor is impregnated with non-PCB oil which in turn helps in effective dissipation of heat which enables optimum performance in hostile ambient and harmonic rich environment.

In addition to this, the presence of impregnated oil increases the Break Down Voltage (BDV) of the capacitor; hence the MDXL capacitor can withstand higher voltage stress thus surely stands out among the conventional self healing capacitors.

- Dielectric: by using Dual side metalized paper as electrode and polypropylene film as dielectric.
- Oil Filled , Non- PCB

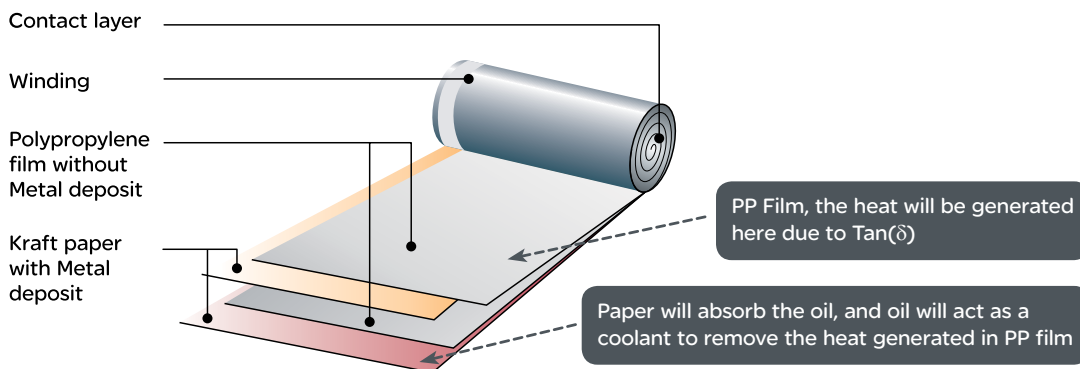

## Technical specifications

General characteristics		
Standards		IEC 60831-1/-2, IS 13340-1993/ IS 13341-1992
Voltage range		440V, 480V, 525V
Frequency		50 / 60 Hz
Power range		5 to 50 kVAr
Losses (dielectric)		< 0.2W/kVAr
Losses (total)		< 0.5W/kVAr
Capacitance tolerance		-5%, +10%
Voltage test	Between terminals	$2.15 \times U_N$ (AC), 10 s
	Between terminal & container	$\leq 525V$ : 3kv(AC), 10s or 3.66kv(AC), 2s $> 525V$ : 3.66kv(AC), 10s or 4.4kv(AC), 2s
	Impulse voltage	$\leq 690V$ : 8kv
Discharge resistor		Fitted, standard discharge time 60 s
Working conditions		
Ambient temperature		-25°C / +70°C (Class D)
Humidity		95%
Altitude		2,000 m above sea level
Overvoltage		$1.00 \times U_N$ - Continuous
		$1.10 \times U_N$ - up to 12 hrs per day
		$1.15 \times U_N$ - up to 30 min per day
		$1.20 \times U_N$ - 5 min
		$1.30 \times U_N$ - 1 min
Overcurrent		Up to $2.5 \times I_N$
Peak inrush current		$400 \times I_N$
Switching operations (max.)		Up to 10,000 switching operations per year
Mean Life expectancy		Up to 160,000 hrs
Installation characteristics		
Mounting position		Indoor, upright
Fastening		Mounting cleats
Earthing		
Terminals		Bushing terminals designed for large cable termination and direct busbar mounting for banking
Safety features		
Safety		Self-healing + Pressure-sensitive disconnecter for each phase + Discharge device
Protection		IP20
Construction		
Casing		Sheet steel enclosure
Dielectric		Double metallized paper + polypropylene film
Impregnation		Non-PCB, oil

# VarplusBox energy, ultra heavy duty (MD-XL)

Varplus BOX Energy, Ultra Heavy Duty (MD-XL) 440V, 3 Phase, 50Hz										
50 Hz		Capacitance (3*mfd)	Reference Number	Dimention					Net Weight (kg)	Case Code
Q <sub>N</sub> (kVAR)	I <sub>N</sub> (Amps)			W1 (mm)	W2 (mm)	W3 (mm)	H (mm)	D (mm)		
5	6.6	27.4	MEHVBENY050A44	263	243	213	260	97	3.6	EB
7.5	9.8	41.1	MEHVBENY075A44	263	243	213	355	97	3.6	DB
10	13.1	54.8	MEHVBENY100A44	263	243	213	355	97	4.8	DB
12.5	16.4	68.5	MEHVBENY125A44	263	243	213	355	97	4.8	DB
15	19.7	82.2	MEHVBENY150A44	309	289	259	355	153	7.5	GB
20	26.2	109.7	MEHVBENY200A44	309	289	259	355	153	7.5	GB
25	32.8	137.1	MEHVBENY250A44	309	289	259	355	153	7.5	GB
30	39.4	164.5	MEHVBENY300A44	309	289	259	497	224	10	IB
50	65.6	274.2	MEHVBENY500A44	309	289	259	497	224	10	IB

480V Capacitors for 5.7% / 7% Detuned filter Application										
Varplus Box Energy, Ultra Heavy Duty (MD-XL), 480V, 3 Phase, 50Hz										
50 Hz		Capacitance (3*mfd)	Reference Number	Dimention					Net Weight (kg)	Case Code
Q <sub>N</sub> (kVAR)	I <sub>N</sub> (Amps)			W1(mm)	W2(mm)	W3(mm)	H(mm)	D(mm)		
5.6	6.7	25.8	MEHVBENY056A48	263	243	213	260	97	3.6	EB
6.7	8.1	30.9	MEHVBENY067A48	263	243	213	355	97	4.8	DB
11.3	13.6	52.1	MEHVBENY113A48	263	243	213	355	97	4.8	DB
12.5	15.0	57.6	MEHVBENY125A48	263	243	213	355	97	4.8	DB
14.4	17.3	66.3	MEHVBENY144A48	309	289	259	355	97	5.4	FB
15.5	18.6	71.4	MEHVBENY155A48	309	289	259	355	97	5.4	FB
17	20.4	78.3	MEHVBENY170A48	309	289	259	355	153	7.5	GB
19	22.9	87.5	MEHVBENY190A48	309	289	259	355	153	7.5	GB
22.4	26.9	103.2	MEHVBENY224A48	309	289	259	355	153	7.5	GB
25	30.1	115.2	MEHVBENY250A48	309	289	259	355	153	7.5	GB
28.1	33.8	129.5	MEHVBENY281A48	309	289	259	355	153	7.5	GB
31.5	37.9	145.1	MEHVBENY315A48	309	289	259	355	153	7.5	GB
56.1	67.5	258.5	MEHVBENY561A48	309	289	259	497	224	10	IB

525V Capacitors for 5.7% / 7% / 14% Detuned filter application										
Varplus Box Energy, Ultra Heavy Duty (MD-XL) 525V, 3 Phase, 50Hz										
50 Hz		Capacitance (3*mfd)	Reference Number	Dimention					Net Weight (kg)	Case Code
Q <sub>N</sub> (kVAR)	I <sub>N</sub> (Amps)			W1 (mm)	W2 (mm)	W3 (mm)	H (mm)	D (mm)		
6.9	7.6	26.6	MEHVBENY069A52	263	243	213	260	97	3.6	EB
12.5	13.7	48.1	MEHVBENY125A52	263	243	213	355	97	4.8	DB
13.8	15.2	53.2	MEHVBENY138A52	263	243	213	355	97	4.8	DB
15.4	16.9	59.3	MEHVBENY154A52	309	289	259	355	97	4.8	FB
17.2	18.9	66.2	MEHVBENY172A52	309	289	259	355	153	7.5	GB
18.5	20.3	71.3	MEHVBENY185A52	309	289	259	355	153	7.5	GB
20.6	22.7	79.3	MEHVBENY206A52	309	289	259	355	153	7.5	GB
22.6	24.9	87.0	MEHVBENY226A52	309	289	259	355	153	7.5	GB
25	27.5	96.3	MEHVBENY250A52	309	289	259	355	153	7.5	GB
27.5	30.2	105.9	MEHVBENY275A52	309	289	259	355	153	7.5	GB
30.6	33.7	117.9	MEHVBENY306A52	309	289	259	355	153	7.5	GB
33.1	36.4	127.5	MEHVBENY331A52	309	289	259	355	153	7.5	GB
37.7	41.5	145.2	MEHVBENY377A52	309	289	259	497	224	10	IB

# VarplusBox mechanical characteristics

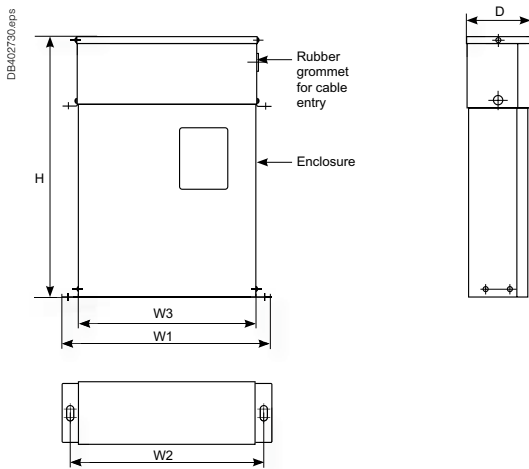

**Case code: DB, EB, FB, GB & HB**

Creepage distance	30 mm
Clearance	
Phase to phase	25 mm (min.)
Phase to earth	19 mm (min.)

**Mounting details: mounting screw M6, 2 Nos.**

Case code	W1 (mm)	W2 (mm)	W3 (mm)	H (mm)	D (mm)	Weight (kg)
DB	263	243	213	355	97	4.8
EB	263	243	213	260	97	3.6
FB	309	289	259	355	97	5.4
GB	309	289	259	355	153	7.5
HB	309	289	259	455	153	8.0

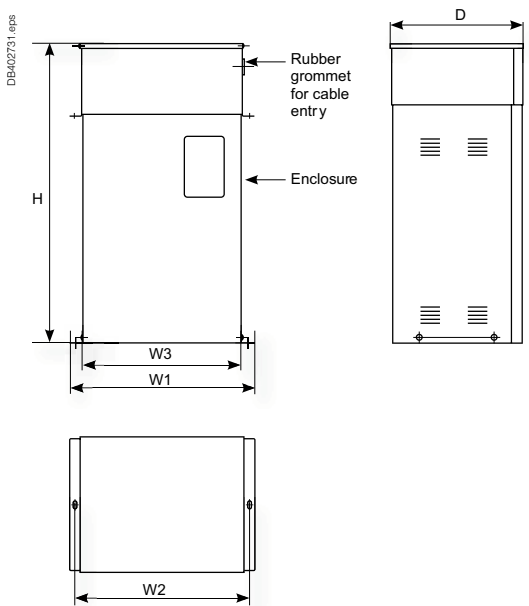

**Case Code: IB**

Creepage distance	30 mm
Clearance	
Phase to phase	25 mm (min.)
Phase to earth	19 mm (min.)

**Mounting details: mounting screw M6, 2 Nos.**

Case code	W1 (mm)	W2 (mm)	W3 (mm)	H (mm)	D (mm)	Weight (kg)
IB	309	289	259	497	224	10.0

# Detuned Reactors

LV - Power Quality Products  
& Solutions

Detuned Reactors

G-2





### Detuned reactors

The detuned reactor (DR) is designed to mitigate harmonics, improve power factor and avoid electrical resonance in low voltage electrical networks.

### Main features

- Special Design to ensure compactness with superior performance
- High level of saturation - Linearity
- High Grade Laminations in Magnetic Circuit
- Easy pad termination and mounting
- Over temperature protection
- Robust inter-turn insulations
- Low losses
- Designed and tested as per IEC 60076 - 6

Technical Details	
Standards	IS 5553, IEC 60076-6
Description	Three phase, dry, magnetic circuit, impregnated
Rated Voltage ( Us)	440V ,50Hz
De-tuning Factor(P)	5.67%(210Hz),7%(189Hz) ,14%(134Hz)
kVAr range	5 to 100 kVAr
Insulation class	H
Inductance tolerance	- 3, + 5%
Harmonic Level	U3 = 0.5% x Us
	U5 = 6.0% x Us
	U7 = 5.0% x Us
	U11 =3.5% x Us
Fundamental Current (Max)	$I_1 = 1.06 \times I_n$ ( rated current)
Duty Cycle (Irms)	100%
Limit of Linearity	$L \geq 0.95 \times L_n$ upto $1.74 \times I_n$
Insulation level	1.1KV
Dielectric test 50Hz between winding/earth	4kv, 1min
Degree of protection	IP00
Thermal protection	Micro switch on terminal block 250V,AC,2A(NC)
Winding material	Aluminum wound

Detuned Factor (P) = 7%, Frequency (Fr)= 189Hz, 440V, Fn=50Hz									
QN (kVAr)	current Irms (A)	Inductance (3*mH)	Reference Number	W (mm)	W1 (mm)	D (mm)	D1 (mm)	H (mm)	Net weight (kgs)
5	7.1	9.04	LVR07050A44	240	200	140	125	220	10.7
10	14.2	4.52	LVR07100A44	240	200	140	125	220	12.7
12.5	17.7	3.61	LVR07125A44	240	200	140	125	220	16.2
15	21.3	3.01	LVR07150A44	240	200	140	125	220	16.2
20	28.4	2.26	LVR07200A44	240	200	140	125	220	21.2
25	35.5	1.81	LVR07250A44	240	200	140	125	220	21.2
50	70.9	0.90	LVR07500A44	260	200	140	125	270	32.2
75	106.4	0.60	LVR07750A44	260	200	140	125	270	43.2
100	148.8	0.45	LVR07X00A44	350	200	160	125	320	44.2

# Detuned reactors

Detuned Factor (P) = 5.67%, Frequency (Fr)= 210Hz, 440V , Fn=50Hz									
QN (kVAr)	current Irms (A)	Inductance (3*mH)	Reference Number	W (mm)	W1 (mm)	D (mm)	D1 (mm)	H (mm)	Net weight (kgs)
5	8.0	7.41	LVR05050A44	240	200	140	125	220	10.7
10	16.1	3.70	LVR05100A44	240	200	140	125	220	12.7
12.5	20.1	2.96	LVR05125A44	240	200	140	125	220	16.2
15	24.1	2.47	LVR05150A44	240	200	140	125	220	16.2
20	32.1	1.85	LVR05200A44	240	200	140	125	220	21.2
25	40.2	1.48	LVR05250A44	240	200	140	125	220	21.2
50	80.4	0.74	LVR05500A44	260	200	140	125	270	30.7
75	120.6	0.49	LVR05750A44	260	200	140	125	270	43.2
100	160.7	0.37	LVR05X00A44	350	200	160	125	320	44.2

Detuned Factor (P) = 14%, Frequency (Fr)= 134Hz, 440V , Fn=50Hz									
QN (kVAr)	current Irms (A)	Inductance (3*mH)	Reference Number	W (mm)	W1 (mm)	D (mm)	D1 (mm)	H (mm)	Net weight (kgs)
5	6.6	19.59	LVR14050A44	240	200	140	125	220	10.5
10	13.2	9.79	LVR14100A44	240	200	140	125	220	13
12.5	16.5	7.8	LVR14125A44	240	200	140	125	220	14.5
15	19.9	6.53	LVR14150A44	240	200	140	125	220	15.5
20	26.5	4.89	LVR14200A44	240	200	140	125	220	27
25	33.1	3.91	LVR14250A44	240	200	140	125	220	27.2
50	66.2	1.95	LVR14500A44	260	200	140	125	270	37.2
75	99.3	1.30	LVR14750A44	260	200	140	125	270	60.2
100	132.4	0.98	LVR14X00A44	350	200	160	125	320	61.2

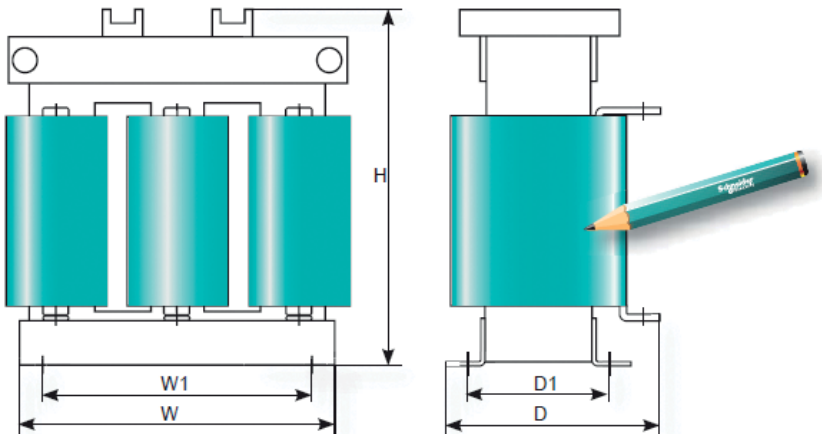





# Power Factor Controllers and Contactors

LV - Power Quality Products  
& Solutions

Varlogic APFC Relay  
Capacitor Duty Contactors

---

H-2  
H-6





RT series

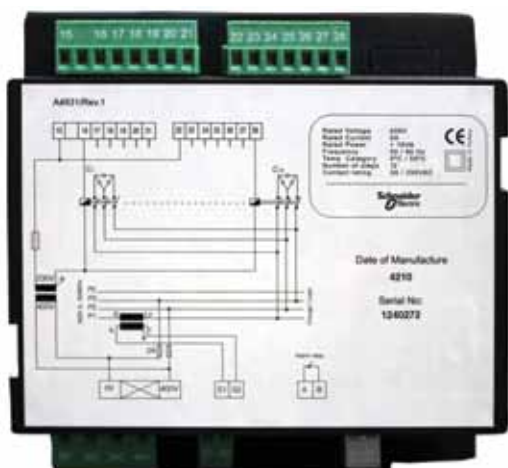

## Technical Specifications - Classic Range

Technical Data	Description
APFC Relay Model	RT6/RT8/RT12
Standards	EMC : IEC 61326, IEC61000-6-2, IEC61000-6-4, Safety IEC/EN 61010-1
No of steps	6, 8 and 12
Rated Voltage ( Un)	320 to 440V AC
Measurement Voltage	2 wire configuration
Current input	5A, Single CT sensing
Operating Current Range	50mA - 5.5A
Frequency (Hz)	50 /60 Hz
Accuracy Measuring Class	1 %+_ 1 digit ( V.I cosQ) 2% +_ 1 digit ( W, var, VA)
Power Consumption	Current : < 2 VA Voltage : 3VA - 10 VA
Out put Contact	3A/250V - 1A/400V
Protection in case of micro cuts in voltage	20 msec. < 30% of nominal voltage
C/K Setting range (Manually Settable)	0.02 - 1.0 CosQ Setting 0.85(ind) - 1.00 Manual or Automatic setting CT Ratio : 5 - 10000
Response Delay Time	Between 10 sec - 1800 sec
Over voltage	Programmable 240 -275V AC ( for 185 --- 265V, AC) 410 - 480VAC( for 320 --- 460V , AC)
Ambient Temperature	0 degree C to 55 degree C
Display	4 Digit , 7 segment, Red LED Display
CT Input Cable (For Terminal Block)	2.5 mm2
Enclosure Material	ABS UL 94 V0
Protection Class	IP41 (Front side) IP20 (Rear side) acc to IEC 60529
Shock Test	IK 06
Terminals	Socket Terminal with Screw
Switchboard cut -out	139 x139mm
Overall Dimension (L x W x D)	143 x 143 x 67
Weight	0.8 Kg

## Technical Specifications - Classic Range

Display Parameters	Power Factor (Cos phi)
	RMS Voltage (V)
	RMS Current (I)
	Active Power (W)
	Reactive Power (VAr)
	Apparent Power ( VA)
Main Features	Automatic C/K Adjustment
	Manual control for operating test
	Microcontroller relay
	Auto CT polarity change-over
	Over-Voltage Protection
	Various Switching Programs
	a) Rotational Switching
	b) Linear Operation
	c) Auto Capacitor selection
Errors and warnings	In correct Voltage or Current connections
	Over Voltage
	Low Power Factor
	Over Compensation
RS 232 / 485 Communication	Nil
Certification	CE

### Ordering Reference Nos

Type	Description	Ordering Reference
RT6	6 step, 440V , 5A	51207
RT8	8 step, 440V, 5A	51209
RT12	12 step, 440V , 5A	51213



NR series



NRC Series

## Technical Specifications - Advanced Range

Varlogic APFC Relay Technical Specifications - Advanced Range		
Technical Data	Description	Description
APFC Relay Model	NR6/NR12	NRC12
Standards	EMC : IEC 61326, IEC61000-6-2, IEC61000-6-4, Safety : IEC / EN 61010 -1	EMC : IEC 61326, IEC61000-6-2, IEC61000-6-4, Safety : IEC / EN 61010 -1
No of steps	6 & 12	12
Rated Voltage ( Un)	110-220/240-380/415 ( Ph - Ph & Ph - N)	110-220/240-380/415 ( Ph - Ph & Ph - N)
Measurement Voltage	110-220/240-380/415	110-220/240-380/415-690V
Current input	Single CT Sensing	1A/5A, Single CT Sensing
Frequency (Hz)	50 /60 Hz	50 /60 Hz
Potential free Output Contact	AC: 1A/400V , 2A/250V, 5A/120V DC: 0.3A/110V, 0.6A/60V, 2A/24V	AC: 1A/400V , 2A/250V, 5A/120V DC: 0.3A/110V, 0.6A/60V, 2A/24V
Settings and Parameter	CosQ Setting: 0.8 ind.....0.9 cap Manual or Automatic setting Choice of different stepping programs	CosQ Setting: 0.8 ind.....0.9 cap Manual or Automatic setting Choice of different stepping programs
Response Delay Time	Between 10 sec - 600 sec	Between 10 sec - 900 sec
Over voltage	Programmable > 110% of Un	Programmable > 110% of Un
Ambient Temperature	0 degree C to 55 degree C	0 degree C to 55 degree C
Display	backlit screen 65 x21mm	backlit graphic screen 55 x 28mm
CT Input Cable (For Terminal Block)	2.5 mm2	2.5 mm2
Protection Class	IP41 ( Front face) IP20 ( Rear face)	IP41 ( Front face) IP20 ( Rear face)
Terminal	Socket Terminal with Screw	Socket Terminal with Screw
Mounting	Mounting on 35mm DIN rail ( EN 50022)	Mounting on 35mm DIN rail ( EN 50022)
Weight	1 Kg	1 Kg
Display Parameters	Power Factor (Cos Phi) Connected steps Switching steps and connected time counter NA NA Network technical data : load and reactive currents, voltage,powers (S,P,Q) Ambient temperature inside the cubicle Total Voltage harmonic distortion THD(U) NA NA NA	Power Factor (Cos Phi) Connected steps Switching steps and connected time counter Step configuration (fixed/ auto/disconnected) Step output status (capacitance loss monitoring) Network technical data : load and reactive currents, voltage,powers (S,P,Q) Ambient temperature inside the cubicle Total Voltage harmonic distortion THD(U) Total Current harmonic distortion THD(I) Capacitor current overload Irms/I Voltage and current harmonic spectrum (orders 3,5,7,11,13)



## Technical Specifications - Advanced Range

Main Features	Insensitive to CT polarity	Insensitive to CT polarity
	Insensitive to phase rotation polarity	Insensitive to phase rotation polarity
	Manual control for operating test	Personalized step sequences possible
	NA	Manual control for operating test
	NA	4 quadrant operation for generator application
	NA	Possibility of a dual cosQ target
	Choice of different switching programs	Choice of different switching programs
	a) Linear operation	a) Linear operation
	b) Normal	b) Normal
	c) Circular	c) Circular
d) optimal	d) optimal	
Low power factor	Low power factor	
Alarms	Hunting( unstable regulation)	Hunting( unstable regulation)
	Abnormal cosQ	Abnormal cosQ
	Over compensation	Over compensation
	Over current	Over current
	Low Voltage	Low Voltage
	Over Voltage	Over Voltage
	Over temperature	Over temperature
	Total harmonic distortion	Total harmonic distortion
	NA	Capacitor current over load ( I rms)
	NA	Capacitor capacitance loss
Low current message	Low current message	
High current message	High current message	
NA	Under Voltage message	
Communication	NA	RS 485 connection
Optional Features	NA	Temperature external probe

## Ordering Reference Nos

Type	Description	Ordering Reference
NR6	6 step,LCD Display , 110V-415V,5A	52448
NR12	12 step, LCD Display, 110V-415V,5A	52449
NRC12	12 step,LCD Display, Dual PF setting, 110V-415V, 1A/5A	52450
Varlogic N accessories	Description	Ordering Reference
NRC 12	Communication RS485 Modbus set for NRC12	52451

Special contactors LC1 D•K are designed for switching 3-phase, single- or multiple-step capacitor banks. They comply with standards IEC 60070 and 60831, NFC 54-100, VDE 0560, UL and CSA.



Contactor

## Operating conditions

There is no need to use choke inductors for either single or multiple-step capacitor banks.

## Specifications

These contactors are fitted with a block of early make poles and damping resistors, limiting the value of the current on closing to 60 IS max. This current limiting increases the life of all the installation's components, especially the fuses and capacitors.

## TeSys capacitor duty contactors (AC control)

- Special Contactors designed for switching 3 phase capacitors
- Conformity to IEC Standards
- Current limitation by the inbuilt damping resistors
- 1NO + 1NC inbuilt auxiliary contact

Ordering Reference Nos			
Voltage	kVAr	Auxiliary contacts	Reference
440V, 50 Hz	12.5 kVAr	1 NO + 1 NC	LC1DFK11*
		2 NC	LC1DFK02*
	16.7 kVAr	1 NO + 1 NC	LC1DGK11*C
		2 NC	LC1DGK02*C
	20 kVAr	1 NO + 1 NC	LC1DLK11*
		2 NC	LC1DLK02*
	25 kVAr	1 NO + 1 NC	LC1DMK11*C
		2 NC	LC1DMK02*C
	33.3	1 No + 2 Nc	LC1DPKB7C
	40 kVAr	1 NO + 2 NC	LC1DTKB7C
	60 kVAr	1 NO + 2 NC	LC1DWKB7C

*Coil Voltage Code			
Voltage	110V	220V	415V
LC1- DFK .....DMK 50/60Hz	F7	M7	N7
LC1DPK.....DWK 50 Hz	F5	M5	N5

# Installation Guide and Annexures

## LV - Power Quality Products & Solutions

Best Practices for Capacitors Installation	I-2
Best Practices for APFC Panel Installation	I-3
Best practices for detuned APFC panel installation	I-4
Important Formulas	I-5





Double Fast-On + Cable



Clamptite



Stud Type

## Terminals

Double Fast-On + Cable

For lower ratings double fast-on terminals with cables are provided (for rating  $\leq 10\text{kVAr}$ )

## CLAMPTITE terminals

The unique finger-proof CLAMPTITE termination is fully integrated with discharge resistors and allows suitable access to tightening and ensures cable termination without any loose connections. Once tightened, the design guarantees that the tightening torque is always maintained. (for rating  $> 10\text{kVAr}$ , up to  $30\text{kVAr}$ )

## STUD Type terminals

- This type of terminals are used for proper current handling capabilities in capacitors of  $40$  &  $50\text{kVAr}$

## Electrical connection

- Select the cable cross section depending on the  $\text{kVAr}$  & voltage rating
- User is recommended to use a cable of minimum temperature withstand capacity of  $90^\circ\text{C}$ . (Recommended is  $105^\circ\text{C}$ )
- Remove conductor insulation of the cable only.  $10\text{mm}$  for connection.
- Suitable size lugs have to be used with connecting cable to capacitor terminals in order to avoid heat generation due to improper contacts, in case of VarplusBox or Stud type VarplusCan.
- Insert conductor fully inside the clamp terminal to ensure that no single strand to come out from the slot, in case of clamp type terminals.
- Please ensure proper tightness when a screw driver is used to avoid loose termination.
- Apply a torque of  $2.5\text{Nm}$  to tighten the CLAMPTITE terminal
- Apply a torque of  $20\text{Nm}$  to tighten the Stud type terminal
- For tightening the VarplusBox terminal studs apply a torque of
  - > For  $\text{M6}$  studs -  $4\text{ Nm}$
  - > For  $\text{M8}$  studs -  $8\text{ Nm}$
  - > For  $\text{M10}$  studs -  $12\text{ Nm}$

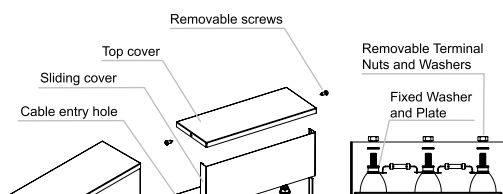
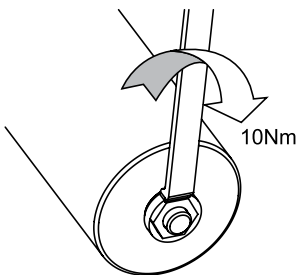
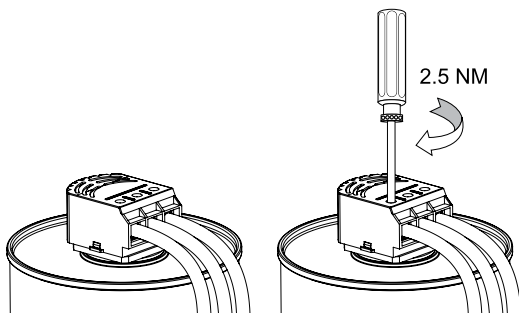

## Mounting

- Varplus capacitors can be mounted alone or in a row.
- Position:
  - > SDuty & Energy : upright
  - > HDuty : upright or horizontal
- Capacitor body should be earthed at bottom.
- Capacitor shall be installed in dry place away from heat generating source & avoid dusty atmosphere
- Provide proper cross ventilation for heat conduction
- Apply a tightening torque of  $8\text{Nm}$  to fix the VarplusBox capacitor on the mounting plates.
- Tightening torque of  $10\text{Nm}$  to be applied on Hexagonal mounting nut for VarplusCan(see picture in the left).



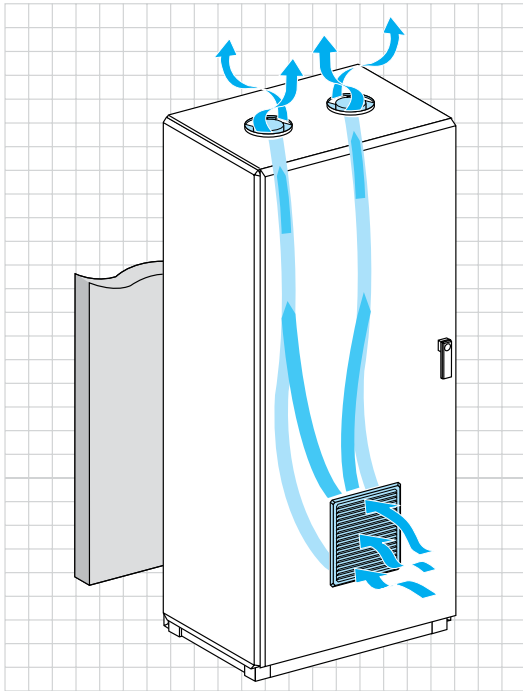

## Ventilation practices

Normal operating conditions according to IEC61439-1

- Maximum temperature in the electrical room:  $\geq 40^{\circ}\text{C}$
- Average temperature over 24hrs in the electrical room:  $\geq 35^{\circ}\text{C}$
- Average annual temperature in the electrical room:  $\geq 25^{\circ}\text{C}$
- Minimum temperature:  $\geq 5^{\circ}\text{C}$
- Maximum altitude:  $\geq 2000\text{m}$

## Ventilation rules:

### Sduty, HDuty & Energy Range

Capacitors, contactors, fuses and electrical connections dissipate heat. These losses are roughly 2-3W/kVAR. Calculate the losses roughly and use the table mentioned in the next page («Minimum number of fans required in the panel»).

The following ventilation rules must therefore be complied with:

- The air within the cubicle must flow upwards.
- It is recommended that extractor fans be fitted on top of the cubicle.
- The bottom air inlet must be as low as possible for better ventilation
- The cross-section of the top air outlet must be more than the cross-section of the bottom air inlet
- The openings must be compatible with the safety rating (IP)
- There should be at least 100 mm between the fan and the modules or components
- The air inlet at the bottom air intake grille must not be obstructed or restricted by a component or module
- Always let a gap of minimum 600 mm between the back of the panel and the wall for a front open panel and a minimum gap of 1000 mm for the rear opened panel. It allows to have a good ventilation
- Take into account the pressure drop of the air inlet and outlet.
- As an indication, the real airflow is 0.6 to 0.75 time the airflow as announced by the fan manufacturer

# Best practices for detuned APFC panel installation

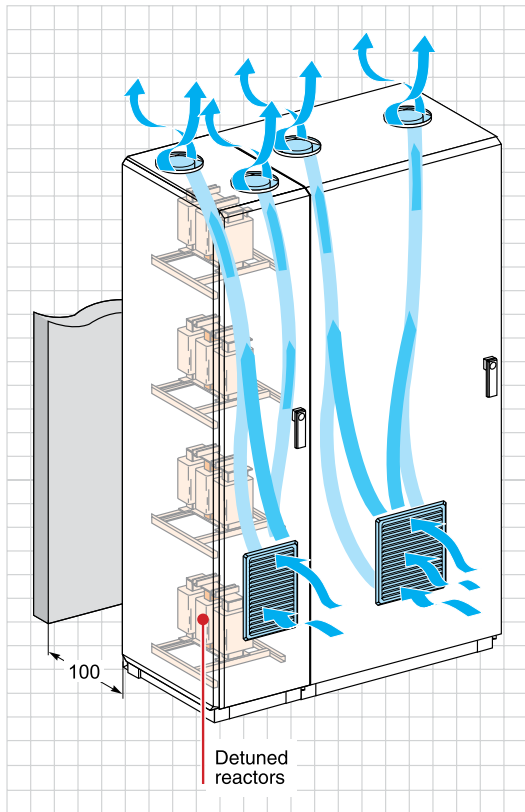

Ventilation for capacitor banks with detuned reactors Capacitors, Detuned Reactors, contactors, fuses and electrical connections dissipate heat:

These losses are roughly 8-9W/kVAr. Calculate the losses roughly and use the table below with respect to Watt losses.

This equipment must always include a forced ventilation system.

- The DRs must be installed: in a separate enclosure or in the same enclosure as the capacitors, but in a separate compartment, or possibly above the capacitors.
- The part of the enclosure containing the capacitors must be ventilated according to the standard capacitor bank rules.
- The part of the enclosure containing the DRs must be ventilated according to the dissipated power.

The ventilation rules in the previous page are applicable here also. Ventilation fans are required with respect to Watt losses. (The designs is made based on the assumption of the system as described above. Any special system conditions need consultation of Schneider Electric. It is always preferred to do thermal study before fixing the ventilation in the panel)

Minimum number of Fans required in the panel(1)	
Total losses	No. of Fans required (2)
0 - 500 W	0
500 - 1500 W	1
1500 - 2400 W	2
2400 - 3000 W	3
3000 - 3500 W	4
3500 - 4500 W	5
4000 - 5000W	6

(2) The air throughput of the fans recommended above is minimum 180m<sup>3</sup> / h (or) Higher size

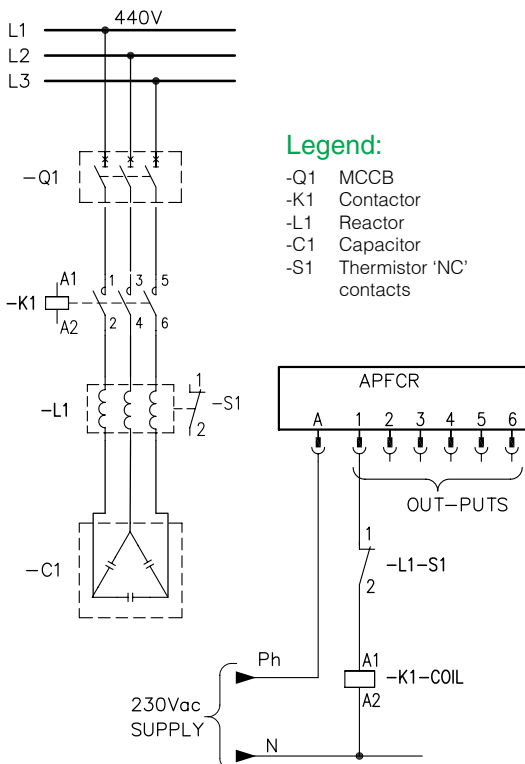

Recommended Enclosure Sizes with can Type Capacitors			
The following table gives the examples for the panel dimentions for better Ventilation			
kVAr rating	Total no.of steps	Panel Dimention ( H x L x W) mm	
		With Reactor	With out Reactor
100	5	1800 x 800 x 800	1800 x 800 x 600
150	6	1800 x 800 x 800	1800 x 800 x 600
200	6	1800 x 800 x 800	1800 x 800 x 600
250	7	2000 x 800 x 800	2000 x 800 x 600
300	8	2000 x 800 x 800	2000 x 800 x 600
350	8	2000 x 800 x 800	2000 x 800 x 600
400	8	2000 x 800 x 800	2000 x 800 x 600

(1) The number of fans recommended and arrived recommendation as per above Panel sizes.

## Importance of Thermistor connection

As the detuned reactor is provided with thermistor 'NC' switch for thermal protection (250VAC, 2A), this 'NC' contact will be used for disconnecting the step switching contactor in case of overheating of the reactors.

### Formula - 1

The kVAr of capacitor will not be same if voltage applied to the capacitor and frequency changes. The example given below shows how to calculate capacitor power in kVAr from the measured values at site and name plate details.

$$Q_M = (f_N / f_M) \times (U_M / U_N)^2 \times Q_N$$

$U_N$  = Rated Voltage

$f_N$  = Rated Frequency

$Q_N$  = Rated power

$U_M$  = Measured voltage

$f_M$  = Measured frequency

$Q_M$  = Available power in kVAr

### Example:

1. Name plate details - 15kVAr, 3 phases, 440V, 50Hz capacitor.  
Measured voltage - 425V  
Measured frequency - 48.5Hz

$$Q_M = (f_N / f_M) \times (U_M / U_N)^2 \times Q_N$$

$$Q_M = (48.5/50) \times (425 / 440 )^2 \times 15 = 13.57\text{kVAr.}$$

2. Name plate details - 25kVAr, 3 phases, 480V, 60Hz capacitor.  
Measured voltage - 464V  
Measured frequency - 59.5Hz

$$Q_M = (f_N / f_M) \times (U_M / U_N)^2 \times Q_N$$

$$Q_M = (59.5/60) \times (464/480 )^2 \times 15 = 23.16\text{kVAr.}$$

### Formula - 2

The current of capacitor will not be same if voltage applied to the capacitor and frequency changes. The example given below shows how to calculate capacitor current from the measured value at site.

$$I_M = I_R \left( \frac{U_M \times f_M}{U_R \times f_R} \right)$$

$U_N$  = Rated Voltage

$f_N$  = Rated Frequency

$I_N$  = Rated Current

$U_M$  = Measured voltage

$f_M$  = Measured frequency

$I_M$  = Capacitor Current

### Example:

Consider a capacitor of 15 kVAr, 440V, 50 Hz, 3 Phase Capacitor  
Rated Current from name plate = 19.68A

Measured Values are: Voltage : 425V , Frequency : 49.5 Hz,

$$I_M = 19.68 \left( \frac{425 \times 48.5}{440 \times 50} \right)$$

$$= 18.43\text{A}$$

*Note: Please ensure that the measurement is done using true RMS clamp meter*

# Important formulas

## Formula - 3

Formula for calculating rated current of capacitor with rated supply voltage and frequency.

$$I_N = kVA_r \times 10^3 / (\sqrt{3} \times U_N)$$

### Example

- 50 kVA<sub>r</sub>, 3 phase, 440V, 50Hz capacitor.

$$I_N = kVA_r \times 10^3 / (\sqrt{3} \times U_N)$$

$$I_N = (50 \times 1000) / (1.732 \times 400)$$

$$I_N = 65.61 \text{ A}$$

- 37.7 kVA<sub>r</sub>, 3 phases, 525V, 50Hz capacitor.

$$I_N = kVA_r \times 10^3 / (\sqrt{3} \times U_N)$$

$$I_N = (37.7 \times 1000) / (1.732 \times 525)$$

$$I_N = 41.45 \text{ A}$$

## Formula - 4

The capacitance value of a capacitor can be calculated using following formulae for delta connected 3ph capacitor.

Assume that capacitance of the three delta connected capacitors are C as shown in the figure.

$$C = Q_N \times 10^9 / (4\pi f_N U_N^2) \text{ for 3 phase capacitor.}$$

### Example

- 15 kVA<sub>r</sub>, 3 phases, 415V, 50Hz capacitor

$$C = 15 \times 10^9 / (4 \times 3.142 \times 50 \times (415 \times 415)) = 138.62 \mu\text{F}$$

- 15 kVA<sub>r</sub>, 3 phases, 440V, 50Hz capacitor

$$C = 15 \times 10^9 / (4 \times 3.142 \times 50 \times (440 \times 440)) = 123.31 \mu\text{F}$$

## Formula - 5

kVA<sub>r</sub> calculation from the measured capacitance value of a capacitor.

$$Q_M = 2/3 \times (C_a + C_b + C_c) \times U_N^2 \times (2\pi f_N) / 10^9 \text{ for 3 phase capacitor.}$$

### Example

- Consider you have measured a capacitor rated for 440volts, 50Hz where in measured capacitance value is as follows:

- 197μf (between R & Y phase) - C<sub>a</sub>
- 196μf (between B & Y phase) - C<sub>b</sub>
- 200μf (between R & B phase) - C<sub>c</sub>

$$Q_M = 2/3 \times (C_a + C_b + C_c) \times U_N^2 \times (2\pi f_N) / 10^9$$

$$Q_M = 2/3 \times (197+196+200) \times (440^2) \times 2 \times 3.14 \times 50 / 10^9 = 24.04 \text{ kVA}_r$$

- Consider you have measured a capacitor rated for 480V ,60Hz where in measured capacitance value is as follows.

- 236μf (between R & Y phase) - C<sub>a</sub>
- 238μf (between B & Y phase) - C<sub>b</sub>
- 237μf (between R & B phase) - C<sub>c</sub>

$$Q_M = 2/3 \times (C_a + C_b + C_c) \times U_N^2 \times (2\pi f_N) / 10^9$$

$$Q_M = 2/3 \times (236+238+237) \times (480^2) \times 2 \times 3.14 \times 60 / 10^9 = 41.19 \text{ kVA}_r$$

The tolerance of capacitance of a capacitor is -5% to +10% of capacitor as specified in the IEC Standards.

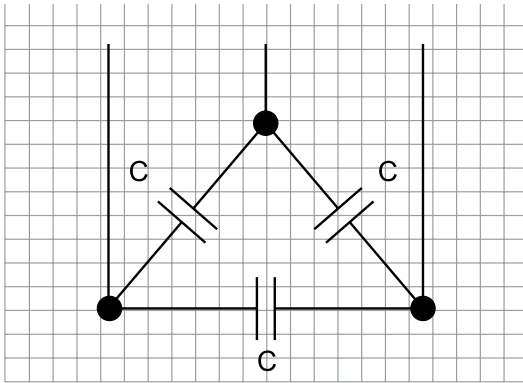





Make the most of your energy<sup>SM</sup>

Schneider Electric India Pvt. Ltd.

**Corporate office**

9th Floor, DLF Building No.10, Tower C, DLF Cyber City,  
Phase II, Gurgaon - 122002, Haryana

Tel: 0124 3940400, Fax: 0124 4222036

[www.schneider-electric.co.in](http://www.schneider-electric.co.in)

**Customer Care Centre:**

Toll-free numbers: 1800 103 0011, 1800 425 4272

General number: 0124 4222040

Email: [customercare.in@schneider-electric.com](mailto:customercare.in@schneider-electric.com)

